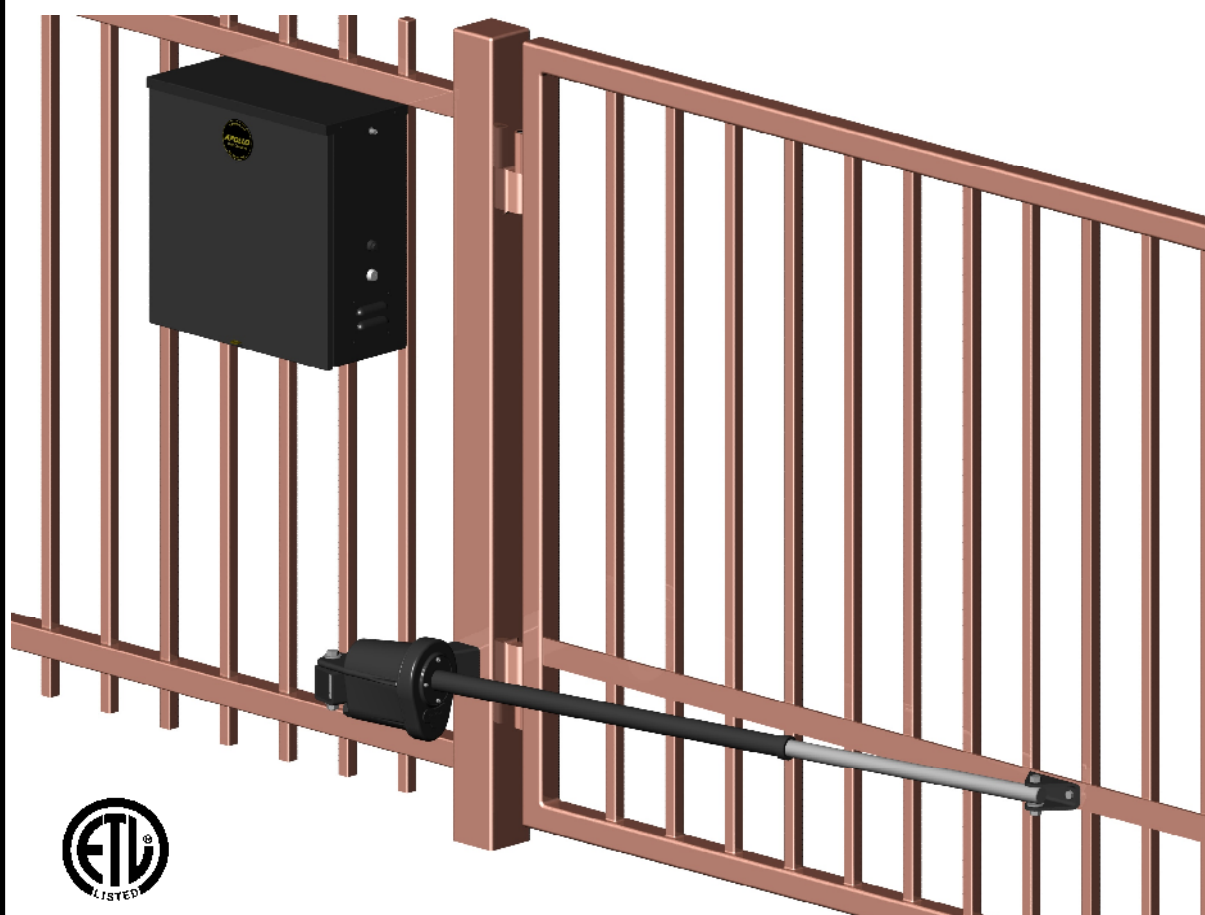


APOLLO *Gate Operators, Inc.*

Model 1550ETL Single Swing Gate Operator

Model 1650ETL Dual Swing Gate Operator



INSTALLATION MANUAL

CONTENTS

IMPORTANT SAFETY INSTRUCTIONS	3
Applications	4
Pre-Installation Checklist	5
Parts Identification	6
Operator Installation	7-9
Pivot Arm Installation	
Actuator Installation	
Control Box Installation	
Connecting the Actuator	
Gate Bracket Installation	
Limit Switch Adjustment	
Control Board Connections	
Control Board Adjustments - Learn Mode	
1550ETL/1650ETL Actuator Option	10
Push to Open Installation	11
Programming Instructions	12
Control Board Description	13-17
Siren Connection	18
Radio Receiver Options	19
Troubleshooting guide	20-22
Warranty	23

IMPORTANT SAFETY INSTRUCTIONS

WARNING - To reduce the risk of injury or death:

- **READ AND FOLLOW ALL INSTRUCTIONS.**
- **Installation should be performed by a professional installer.**
- **Required welding should be performed by a qualified welder.**
- **Should electricity be required, use a certified electrician only.**
- **Any device that requires 120 Volts AC should be U.L. approved.**
- **Review with the owner all safety concerns including:**
 - ⇒ **Do not operate the gate unless area around gate is in full view.**
 - ⇒ **Never let children operate or play with gate controls. Keep the remote control away from children.**
 - ⇒ **Always keep people and objects away from the gate. NO ONE SHOULD CROSS THE PATH OF THE MOVING GATE.**
 - ⇒ **Periodically test the obstruction sensitivity to assure safe and proper operation. *Do not test sensitivity by standing between the gate and the hinge or stop post.***
 - ⇒ **The “CAUTION AUTOMATIC GATE” signs should be clearly visible from both sides of the gate.**
 - ⇒ **Always insure that the gate has closed securely before leaving area.**
 - ⇒ **Arrange with local fire and law enforcement for emergency access.**
- **Use the emergency release only when the gate is not moving.**
- **A secondary entrapment device such as loop detectors, edge switches, and beam detectors are highly recommended and required to meet the UL325 standard.**
- **Install control devices such as keypads far enough away (5 feet or further) from any moving parts of the operator and gate to prevent possible injury.**
- **Do not install control box where the gate can come in contact with person using the push button on side of control box.**
- **Always disconnect the battery or power source when making adjustments or repairs to any part of the gate or operator.**
- **All rollers should be covered to prevent injury.**
- **KEEP GATES PROPERLY MAINTAINED. Read the owner’s manual. Have a qualified service person make repairs to gate hardware.**
- **The entrance is for vehicles only. Pedestrians must use separate entrance.**

Test the gate operator monthly. The gate MUST reverse on contact with a rigid object or stop when an object activates the non contact sensors. After adjusting the force or limit of travel, retest the gate operator. Failure to adjust and retest the gate operator properly can increase the risk of injury or death.

SAVE THESE INSTRUCTIONS.

APPLICATIONS

The **Apollo** Model 1550ETL/1650ETL Swing Gate Operator is approved for **Vehicle Class I & II** usage under **UL 325** Guidelines, and is designed to handle swing gates up to 16 feet in length and 600 pounds each. A professional fence or gate dealer is recommended to assure proper installation. **Apollo Gate Operators** are available only through qualified dealers with an outstanding reputation in the fence and gate industry. These dealers will be able to recommend the proper equipment for particular applications. **Apollo Gate Operators** are 12 Volt DC (*Direct Current*) powered. A 12 Volt sealed battery (33 ampere hour minimum) with connecting posts located on the top is recommended. There are several advantages with 12 Volt DC systems:

- **Low voltage virtually eliminates risk of electrical shock.**
- **Battery powered operators provide up to 200 operations in the event of power outages.**
- **The battery may be recharged with a trickle charger or by solar energy (Electrical battery chargers should have a class 2 transformer rating).**

If a trickle charger is used and a standard electrical outlet is not readily available, a licensed electrician will be required for proper electrical hook up.

The following table should be used as a guide for capacity of operation of operators only, additional options may reduce the the daily usage. *Please note that the charge capability of solar panels will vary with different geographical locations.*

Daily Cycles →	1-10	1-20	1-40	1-60	1-80	80+
5 watt solar panel	*					
10 watt solar panel		*				
20 watt solar panel (<i>requires 5310 regulator</i>)			*			
30 watt solar panel (<i>requires 5310 regulator</i>)				*		
40 watt solar panel (<i>requires 5310 regulator</i>)					*	
1.5 amp battery charger					*	
10 amp battery charger						*

Note: Double the amount of solar panels for Dual Gate Operators.

PRE-INSTALLATION CHECKLIST

The following check list should be used before beginning installation:

Verify that the proper operator has been selected for this application.

Verify proper installation and operation of the gate.

- 1. Are the hinges servicable?*
- 2. Does the gate swing free and level?*
- 3. Will the gate require a locking device?*
- 4. Is the hinge and stop posts sturdy enough to handle the gate & operator?*
- 5. Does the gate meet U.L. construction?*

Determine the general location of the operator, attachment points, and solar panel (if used).

- 1. Is there a suitable location for the operator?*
- 2. Can the solar panel (if used) be mounted in an unobstructed area facing south (in the northern hemisphere)?*
- 3. Will additional solar panel cable be required?*
- 4. Is electricity available (if required)?*

Consider safety and access options. Recommend if needed.

- 1. Will there be children or animals in the area?*
- 2. Are safety loops, edge switches, or photo beam detectors required?*
- 3. How can the gate be opened in emergencies?*
- 4. How will visitors enter and exit?*
- 5. Will vehicles (and trailers) have sufficient room off roadway to operate any control devices such as keypads?*

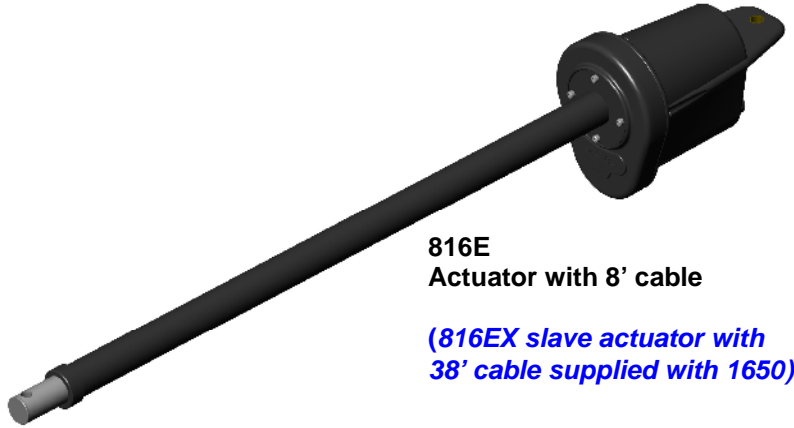
IMPORTANT

Never weld parts to the gate or posts when the operator circuit board is powered. Doing so may damage the board beyond repair.

PARTS IDENTIFICATION



#11111B
Control Box

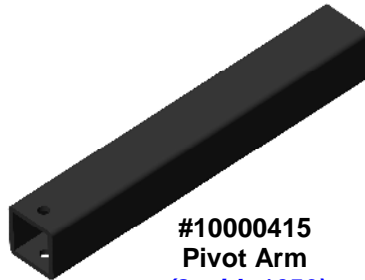


816E
Actuator with 8' cable

(816EX slave actuator with 38' cable supplied with 1650)



#273G
CAUTION Signs (2 each)
(4 each with 1650)



#10000415
Pivot Arm
(2 with 1650)

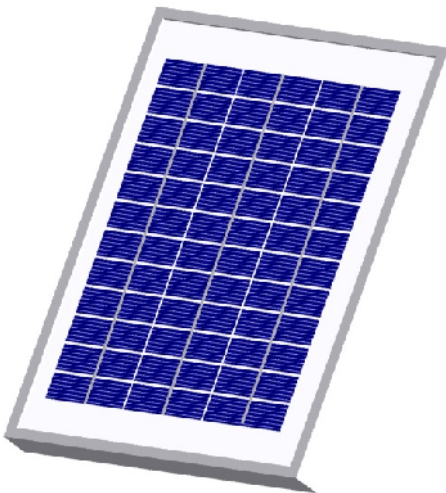


#10025215
Gate Bracket
(2 with 1650)



#1125
Hardware Kit
(2 with 1650)

OPTIONS



#201
5 Watt Solar Panel & Bracket
(optional)
(2 required with 1650)



#404C
Automatic Battery Charger (optional)



#446
Bolt On Pivot Arm (optional)
(2 required with 1650)

OPERATOR INSTALLATION

STEP 1 PIVOT ARM INSTALLATION (standard pull to open)

Location of Pivot Point.

Notes:

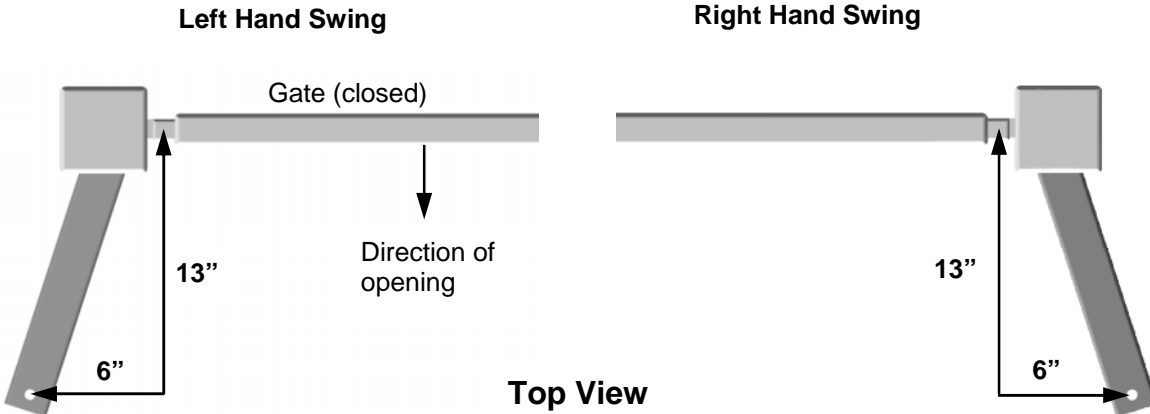
PULL TO OPEN pulls gate open (*actuator is extended when gate is in the closed position*).

PUSH TO OPEN pushes the gate open (*actuator is retracted when gate is in the closed position*).

For PUSH TO OPEN installations see page 12.

If a 400 Upgrade Kit is to be used, refer to the 400 instructions for pivot point location.

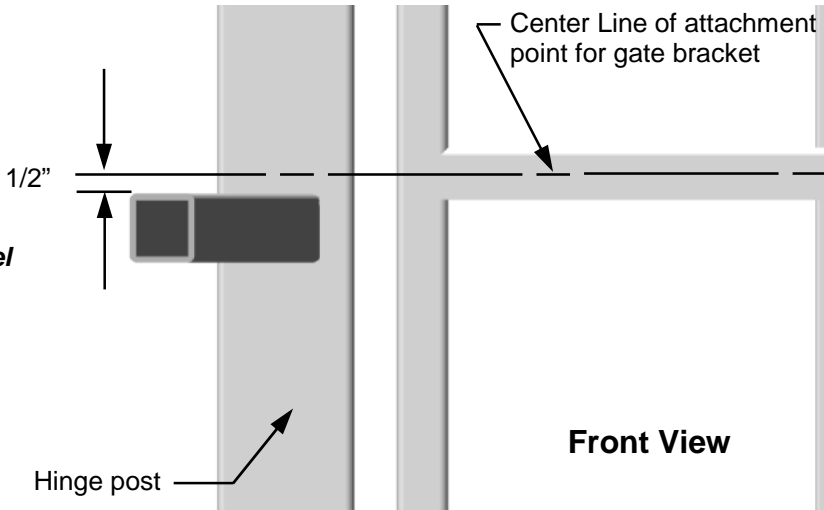
The following instructions provide up to 105° of swing.



Measurements are taken from the center of the hinge.

Vertical position of pivot arm

Pivot Arm Must be level

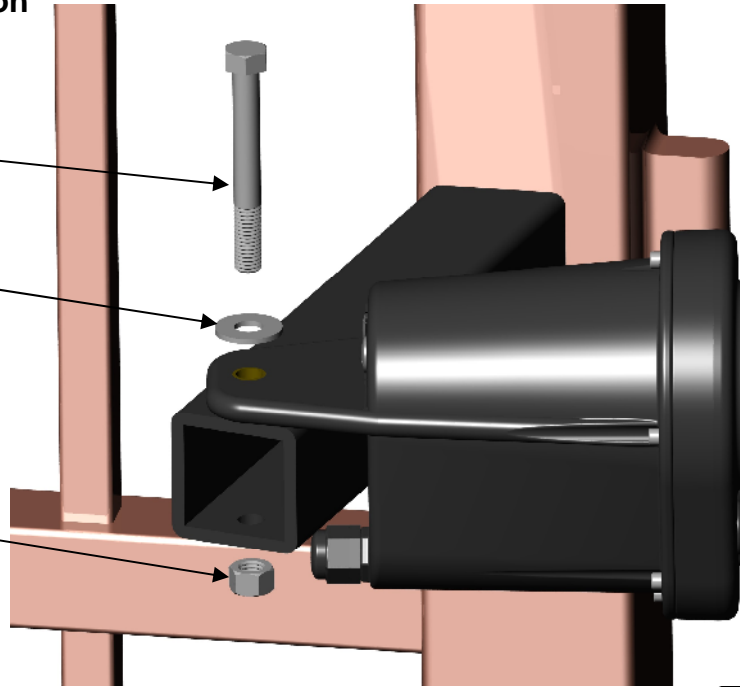


STEP 2 Actuator Installation

1/2" x 3 1/2" Hex Bolt

1/2" Washer

1/2" Lock Nut

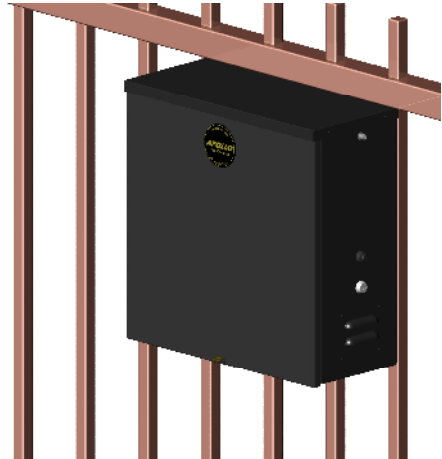


Do not over tighten nut

STEP 3 Control Box Installation

Mount the control box within 4 feet of the pivot arm. **Do not mount the control box where the person using the push button on side of the box can come in contact with the gate.** Use mounting hardware capable of supporting the weight of the control box with the battery installed.

Set battery inside of control box with terminals toward the front (*Do not use any battery with side terminals*).

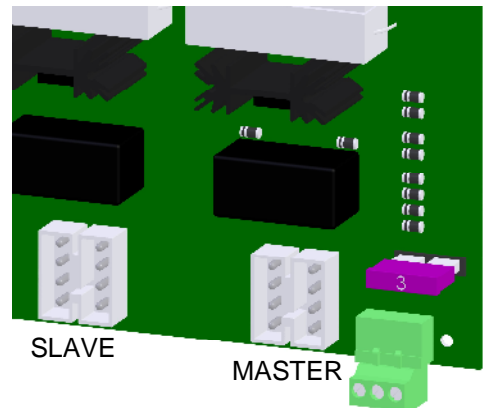


STEP 4 Connecting the Actuator (s)

Connect actuator cable to the "MASTER" connector on the control board.

If a 1650 Dual Operator is being installed and conduit is being used under the drive (recommended), cut the slave (opposite side where control box is mounted) actuator cable about 12" from the white connector. Run the remaining cable across the drive through conduit and up through the control box. Cutoff any excess cable and splice the short piece back to the cable.* Connect to the "SLAVE" connector on the control board.

Connect the RED power wire (s) to the battery positive (+) and the BLACK power wire (s) to the battery negative (-)



* Instead of cutting the slave cable, remove the pins on the plug with a jeweler's common blade screwdriver or appropriate tool (*the staples on the actuator shipping carton work great*), run the cable through the conduit and reinsert the pins into the plug.

IMPORTANT

Never weld parts to the gate or posts when the operator circuit board is powered. Doing so may damage the board beyond repair.

STEP 5 GATE BRACKET INSTALLATION

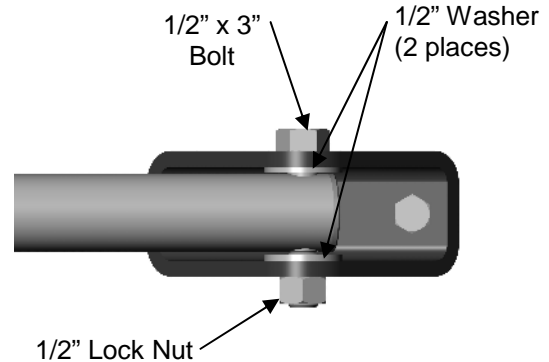
Activate push button on the side of the control box and extend the actuator until it stops (**PULL TO OPEN only, leave actuator retracted for PUSH TO OPEN**).

WARNING: Do not let extension tube rotate as it extends. Do not insert fingers or tools in the hole at the end of the extension tube

Align the hole in the end of the actuator extension tube with the holes in the gate bracket and locate gate bracket mounting position with the gate in the closed position. Weld or bolt the gate bracket to the gate using 3/8" bolts, lock washers, and nuts.

Tip: Tack weld or C clamp at first if uncertain about location. Run the unit through a complete cycle to insure proper operation then mount permanently .

Bolt the actuator to the gate bracket as shown.



STEP 6 Limit Switch Adjustment

Cycle the operator and adjust limits as required. If the operator opens automatically after closing, extend less until gate remains closed.

Do not retract the extension tube too far or the retract limit switch will not be activated. (You can depress the **LED ENABLE** button on the control board to see when the actuator has reached it's limit)

1650 Adjustments

As you open and close the gates, you will notice that the slave side moves 2-3 seconds slower than the master.

Tip: By welding stop tabs on the top and bottom of the master side, the two gates may now be adjusted so the slave gate will close against the stop tabs of the master gate and create enough tension to prevent gates from moving back and forth.

Remove limit switch end caps



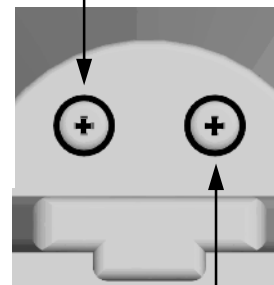
Extend Limit Screw

To **Extend More**
Turn Extend Limit Screw Counter-Clockwise

To **Retract More**
Turn Retract Limit Screw Clockwise

To **Extend Less**
Turn Extend Limit Screw Clockwise

To **Retract Less**
Turn Retract Limit Screw Counter-Clockwise



Retract Limit Screw

1550ETL / 1650ETL Actuator Option

The Apollo **1550ETL** and **1650ETL** systems – which use the **835/836** boards – come standard with the **816E / 816EX** actuators. These actuators have a gray cable restraint and are considered our “smart” or “intelligent” actuator. These actuators utilize all of the features of the **835/836** board.

Please note that if a **416** (non-intelligent actuator) is to be used on a **1550ETL / 1650ETL** system:

1. Switch #10 (SMART ACT.) must be in the **OFF** position.
2. The “slow start” / “slow stop” feature of the **835/836** board will not work with the **416** actuators.

The rest of the set-up and operation of the system is the same as with the “smart” actuators. For example, limit switches on the actuator must be set before proceeding with the current sensing procedure.

Cable Length of 816E / 816EX Actuators

It is not recommended to lengthen or shorten the cables of these actuators – as they have a sensor in the actuator. Should special length cables be required, they are available by special order in any length up to 50 feet.

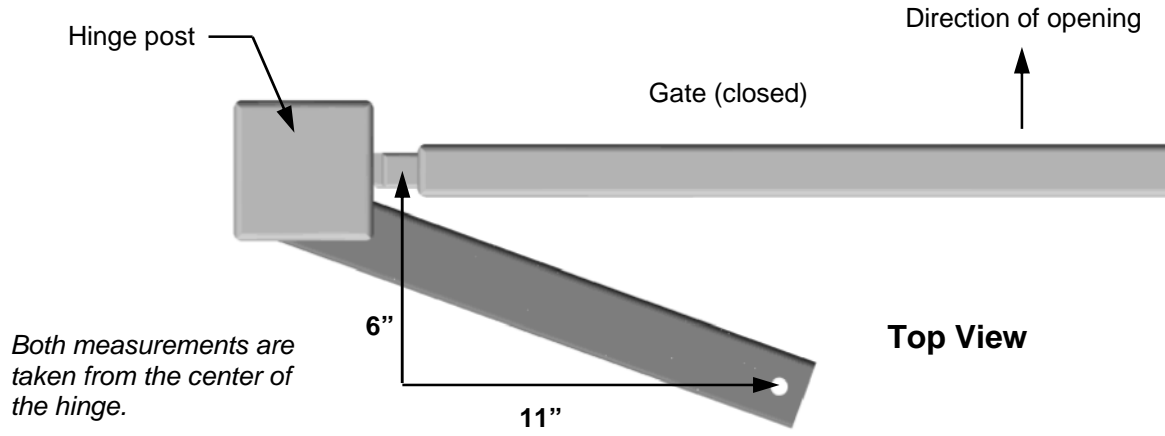
If it is necessary to cut the cable, special attention should be given to ensure that proper electrical splices are performed.

Should the cable of the **816E / 816EX** actuator need to be pulled thru conduit, it is recommended that the plug be removed, cable pulled, then the plug re-installed. (Specific instructions for this are available from your distributor or Apollo Technical Assistance.)

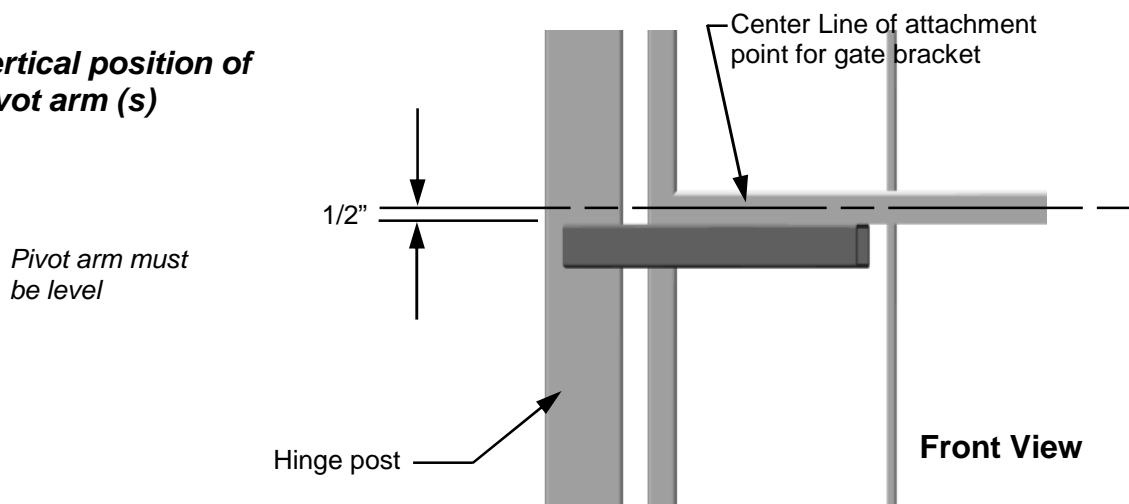
PUSH TO OPEN INSTALLATION

STEP 1 PIVOT ARM (s) INSTALLATION

Location of pivot point

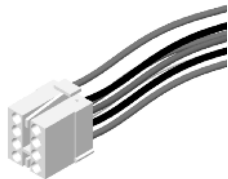


Vertical position of pivot arm (s)



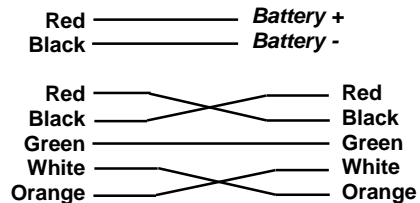
Rewiring actuator (s) for push to open

Must be re-wired for proper operation



8 Pin Connector (s)

Strip back 6" of black sleeve from connector end of the actuator cable. Cut and reconnect the white/orange and the red/black motor wires as shown:



Another method of changing the wiring configuration is to remove the pins on the plug with a jeweler's common blade screwdriver or appropriate tool (*the staples on the actuator shipping carton work great*) and reinsert as shown above.

PROGRAMMING INSTRUCTIONS

The **835/836** circuit boards incorporate a safety feature that will put the operator into a hard shutdown mode if the circuit board detects a current sense two consecutive times during a cycle. This hard shutdown condition can only be reset by shorting the **FIREBOX** or **UL** connectors on the left side of the circuit board to ground. If a firebox is used in the installation, The firebox door should be opened and closed to reset the circuit board.

Once the operator is installed or if the control board is replaced, you will need to program the control board for proper current sensing. The operator should be functional and the open and close limits set.

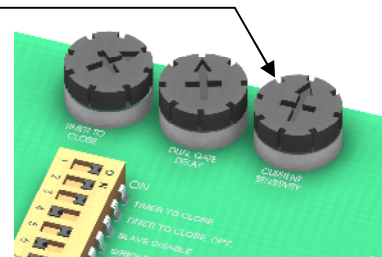
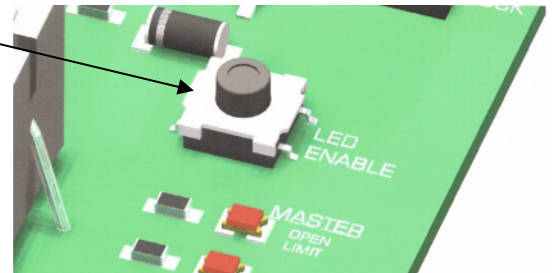
1. Push and hold the **LED ENABLE** button for five seconds.

The **“STOP”** LED will blink indicating the board is in learn mode.

2. Cycle the gate three full times (*must reach the open and close limit switches on each cycle*).

The **“STOP”** LED will now stay illuminated.

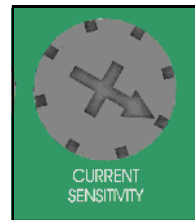
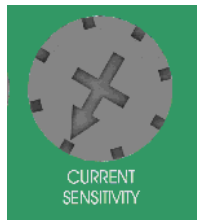
3. Adjust the current sensitivity pot to insure safe operation



COUNTER CLOCKWISE

More sensitivity

Gate is easy to current sense



CLOCKWISE

Less sensitivity

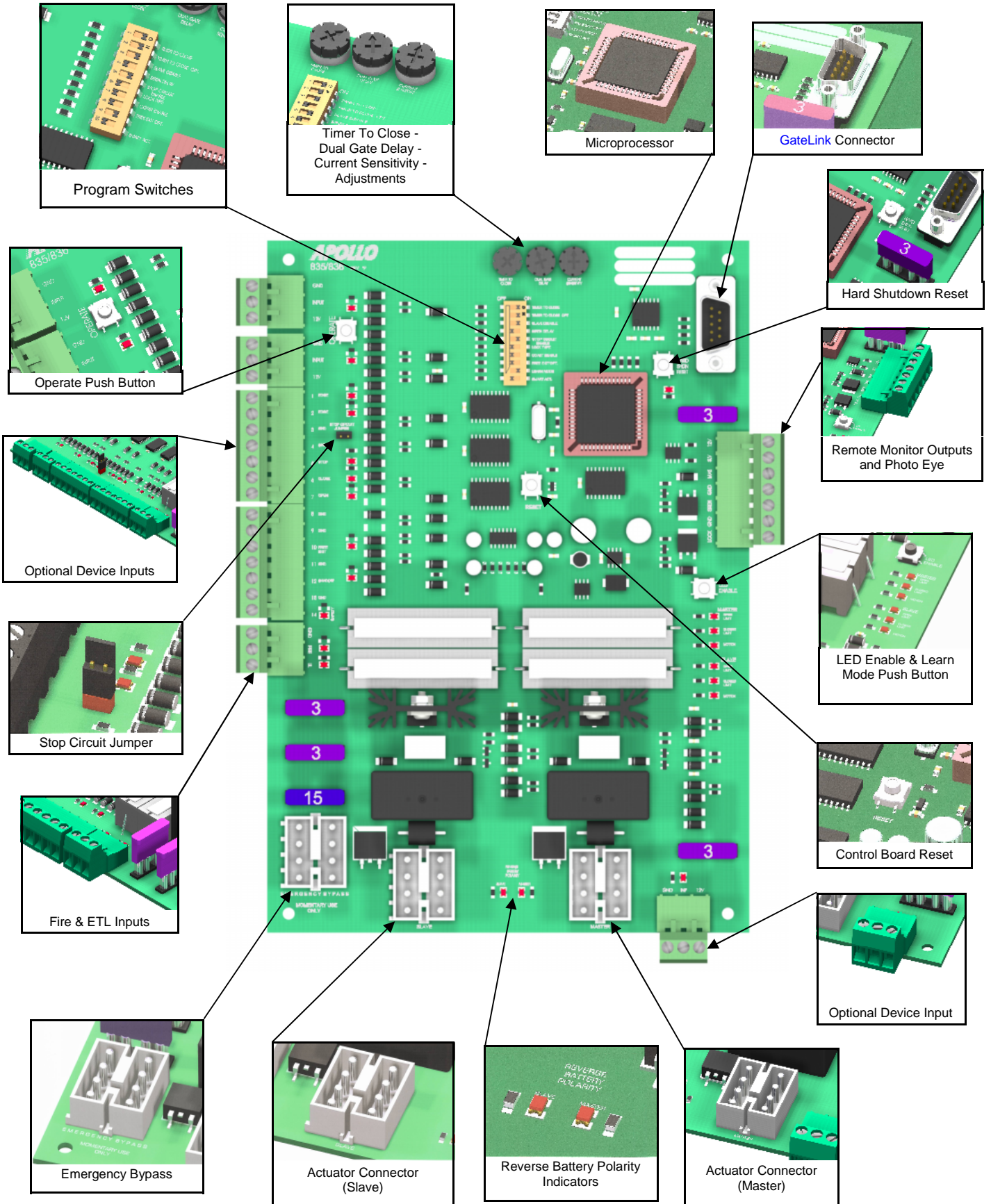
Gate is harder to current sense



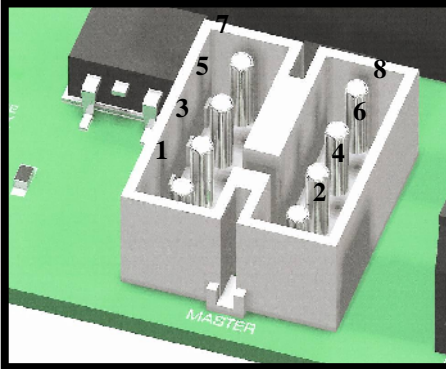
The current sensitivity may be readjusted at any time without relearning the board.

Periodically check the current sensitivity for safe operation.

835/836 Control Board Parts Identification

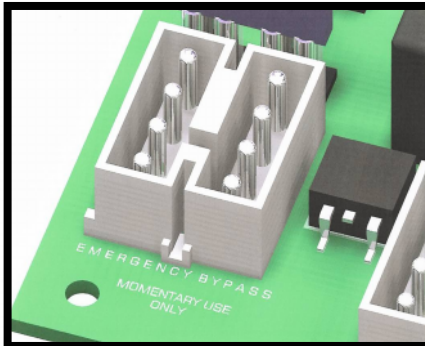


Actuator Connector



Board	Actuator Cable	Function
Pin 1	Orange	Open Limit
Pin 2	White	Close Limit
Pin 3	Black	Motor (positive on open, negative on close)
Pin 4	Red	Motor (negative on open, positive on close)
Pin 5	Green	Common for both limit switches
Pin 6	Yellow	Feedback from intelligent actuator(816E/816EX)
Pin 7	Black	Battery Negative
Pin 8	Red	Battery Positive

EMERGENCY BYPASS (open only)



Applies battery voltage directly to motor to open gate if control board fails. User must unplug before gate opens to maximum travel or 15 amp fuse will open. Fuse should be checked before returning gate to service.

Remote Outputs and Photo Eye Hookup

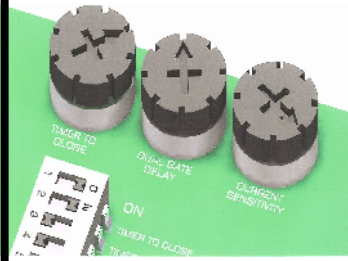
12V	Supplied battery voltage
MAS	Master Operator Indicator (indicates master side of gate is closed) +12V when on closed limit. Ground when off of closed limit.
SLV	Slave Operator Indicator (indicates slave side of gate is closed) +12V when on closed limit. Ground when off of closed limit.
GND	Battery supplied ground
SIREN	Connect to siren + applies +12V when gate(s) are running, or in hard shutdown
GND	Battery supplied ground
LOCK	Connect to lock + (optional) Magnetic or Solenoid type locks (Dip Switch #6 Selectable)

Photo Eye Hookup

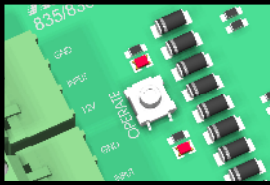
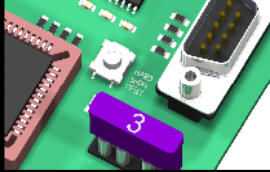
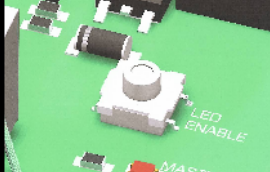
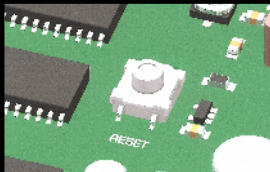


Photo eye / safety loop wiring. Connect the positive power wire of the accessory to 12V. Connect the ground wire of the accessory to MAS (upper right area of the 835/836 board). Connect the relay wires of the accessory as normal: COM to GND. NO to SAFETY (#14) (for a safety device). When the gate operator begins opening (comes off of the closed limits) the MAS terminal will become a ground and will complete the flow of power to the accessory. This will power the accessory up and it will work as normal until the gate gets closed and the MAS terminal switches and the device will power down.

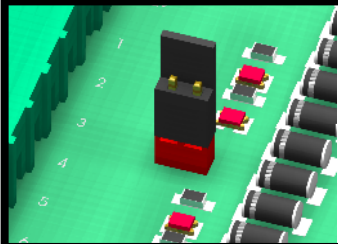
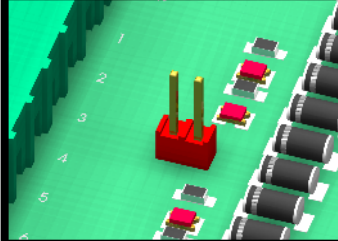
Adjustments

	<p>TIMER TO CLOSE Adjusts time before gate automatically closes. Adjustable 5 to 70 seconds.</p>
	<p>DUAL GATE DELAY Adjusts delay between master and slave operation 0-4 seconds (836 only for use with magnetic, solenoid, and other locking devices)</p>
	<p>CURRENT SENSITIVITY Increases or decreases the Auto Reverse sensitivity.</p>

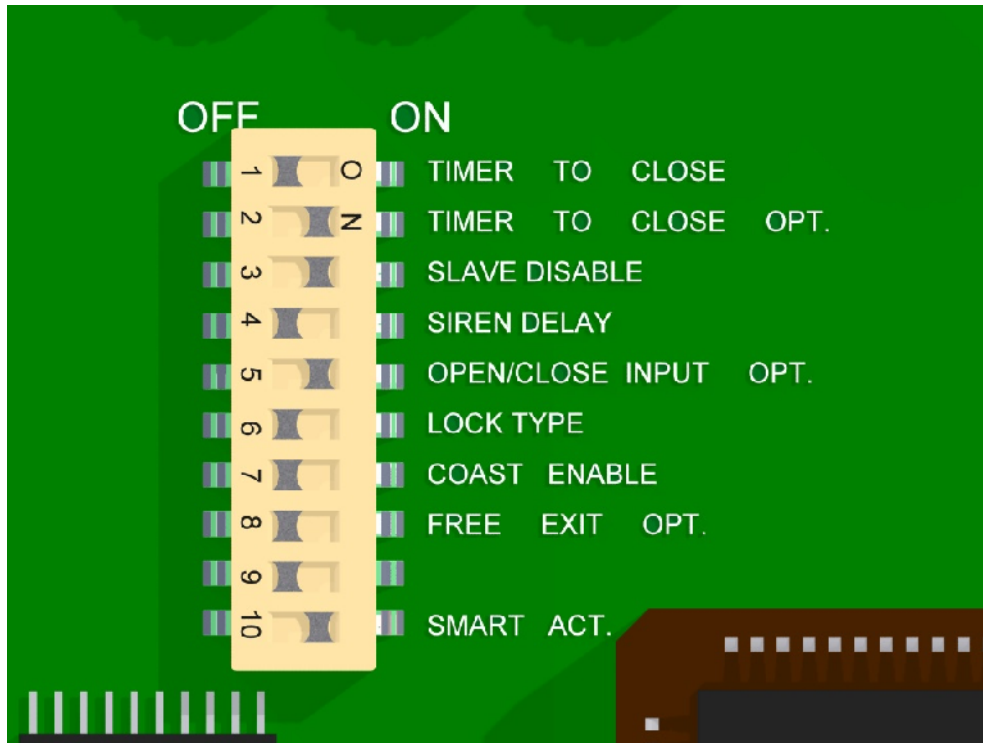
Push Buttons

	<p>OPERATE When depressed, activates the gate. Used for initial installation and testing.</p>
	<p>Hard Shutdown Reset Resets the operator when the gate current senses twice before fully opening or closing.</p>
	<p>LED ENABLE When depressed, activates LEDs for 15 minutes to assist in installation and troubleshooting.</p> <p>Hold the push button down for five seconds to put the board in program mode.</p>
	<p>RESET Resets the microprocessor. Returns processor to last known state.</p>

Jumpers

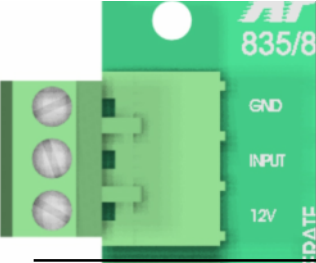

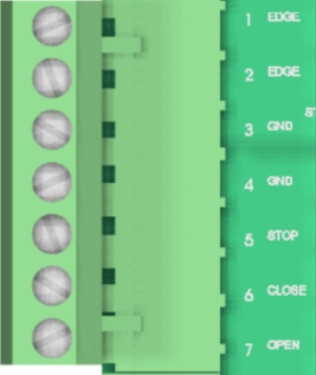
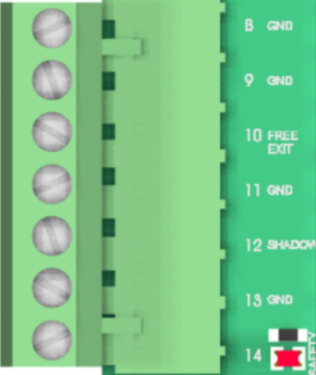
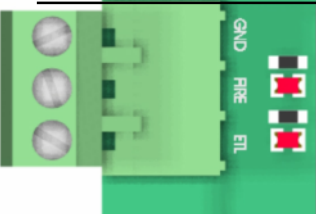
	<p>STOP CIRCUIT JUMPER When the STOP CIRCUIT JUMPER is connected, the gate will operate normally.</p> <p>program switch #5 must be ON</p>
	<p>STOP CIRCUIT JUMPER When a 3-button station is connected to the board, the STOP CIRCUIT JUMPER must be removed.</p> <p>program switch #5 must be OFF</p>

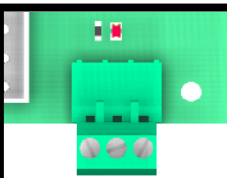
Program Switches



	OFF	ON
1 TIMER TO CLOSE	Gate does not automatically close.	Gate automatically closes.
2 TIMER TO CLOSE OPT.	Gate automatically closes from any position after opening.	Gate automatically closes only when completely open (open limit engaged).
3 SLAVE DISABLE	Enables slave side (dual gate use).	Disables slave side. (single gate use)
4 SIREN DELAY	Siren (optional) active when gate is moving.	Siren (optional) starts 5 seconds before gate moves.
5 'STOP' CIRCUIT ENABLE	Must hold down open or close buttons to move gate. Gate stops when button released.	Normal operation Momentary open or close input runs gate to limit.
6 LOCK TYPE	For 12V mechanical (solenoid) locks. <i>(+12V for 4 seconds on open cycle)</i>	For 12V magnetic locks. <i>(+12V when on close limit)</i>
7 COAST ENABLE	Gate will stop immediately when at Open or Close limit	Gate will coast (minimally) when it reaches limits. Recommended for 7500 slide operator only.
8 FREE EXIT OPT.	A free exit input will open gate from closed position or after a close cycle only.	A free exit input will open gate from any position after an open or close cycle.
9 DUAL GATE SYNC	Both gates operate at normal Speed (slave slower than Master).	This feature will control the master gate to open or close at the same speed as the slave gate.
10 SMART ACT.	Off for 416E & 416EX actuators, slide gates, 3500 or when slow down feature is not desired.	Used for 816E & 816EX actuators only (soft start & stop).

Optional Device Inputs

	835/8 GND	GND	Supplied Battery Ground
	INPUT	INP	Activate Gate (Push button activation when momentarily shorted to ground)
	12V	12V	Supplied Battery Voltage (Protected with 3 Amp fuse)
	GND	GND	Supplied Battery Ground
	INPUT	INP	Activate Gate (Push button activation when momentarily shorted to ground)
	12V	12V	Supplied Battery Voltage (Protected with 3 Amp fuse)
	1 EDGE	EDGE	Reverse edge input. When grounded, will stop and reverse gate if closing, resets close timer if gate is open.
	2 EDGE	EDGE	Reverse edge input. When grounded, will stop and reverse gate if closing, resets close timer if gate is open.
	3 GND	GND	Supplied Battery Ground
	4 GND	GND	Supplied Battery Ground
	5 STOP	STOP	Stop input from a 3 button station (must remove STOP CIRCUIT JUMPER) Normally closed
	6 CLOSE	CLOSE	Close input from a 3 button station (see program switch #5 for options)
	7 OPEN	OPEN	Open input from a 3 button station (see program switch #5 for options)
	8 GND	GND	Supplied Battery Ground
	9 GND	GND	Supplied Battery Ground
	10 FREE EXIT	FREE EXIT	Opens gate if closed, stops and reverses gate if closing, resets close timer if gate is open.
	11 GND	GND	Supplied Battery Ground
	12 SHADOW	SHADOW	Resets close timer when gate is open (also referred to as under gate loop)
	13 GND	GND	Supplied Battery Ground
	14 SAFETY	SAFETY	Resets close timer if gate is open, stops and reverses if gate is closing. (Does not open a closed gate)
	GND	GND	Supplied Battery Ground
	FIRE	FIRE	When grounded, opens gate and holds gate open until released. Clears "Hard Shutdown" mode of software.
	UL	UL	When grounded, opens gate and holds gate open until released. Clears "Hard Shutdown" mode of software.

	GND	GND	Supplied Battery Ground
	INP	INP	Activate Gate (Push button activation when momentarily shorted to ground)
	12V	12V	Supplied Battery Voltage (Protected with 3 Amp fuse)

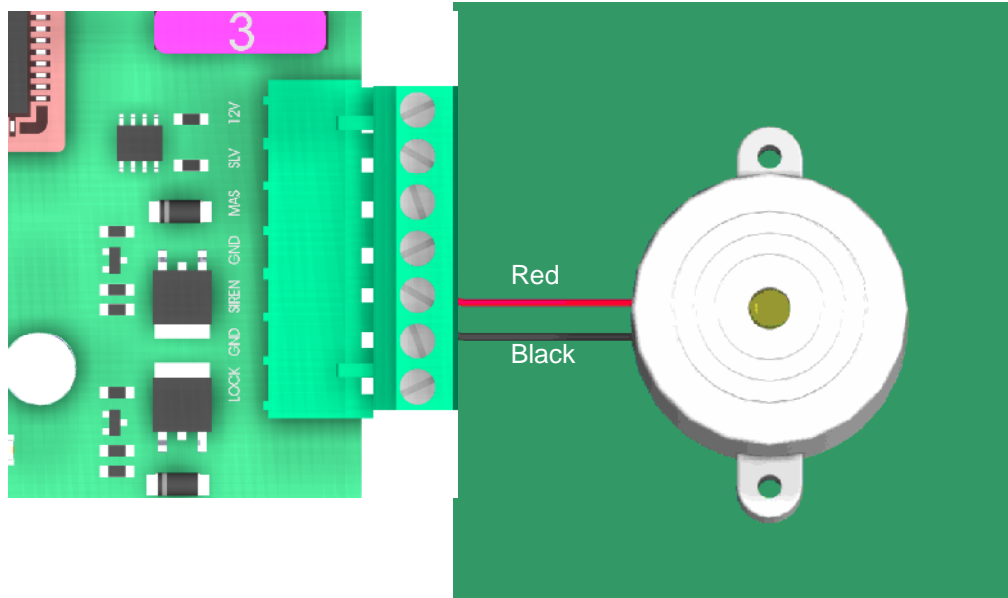
911 Siren

The 911 Siren is included with all Apollo ETL Gate Operators.

Mount siren in an area that will produce maximum performance (additional wire may be required).

Connect the red wire to the SIREN connector on the Remote Monitor Output Connector block.

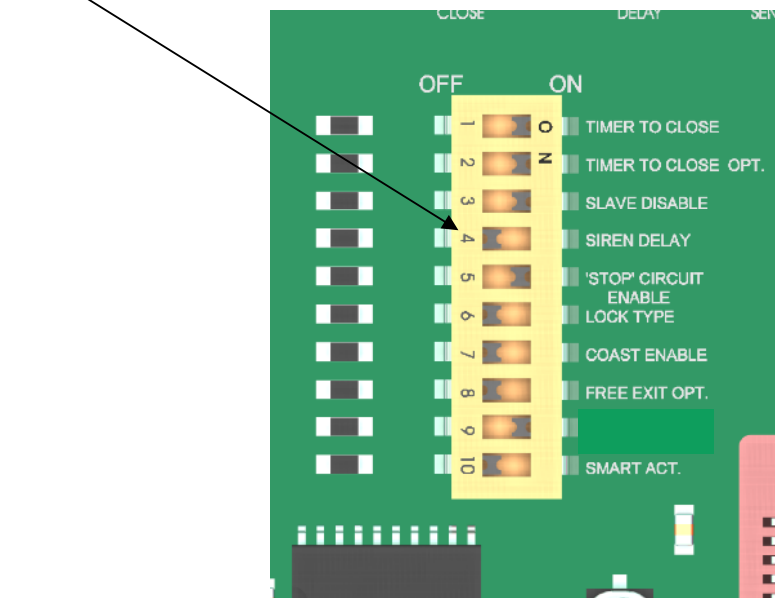
Connect the black wire to the GND connector on the Remote Monitor Output Connector block.



Set Program Switch # 4 as preferred:

ON - Upon activation, Siren will start for 5 seconds before gate(s) begin moving.

OFF - Siren and gate(s) start immediately upon activation.

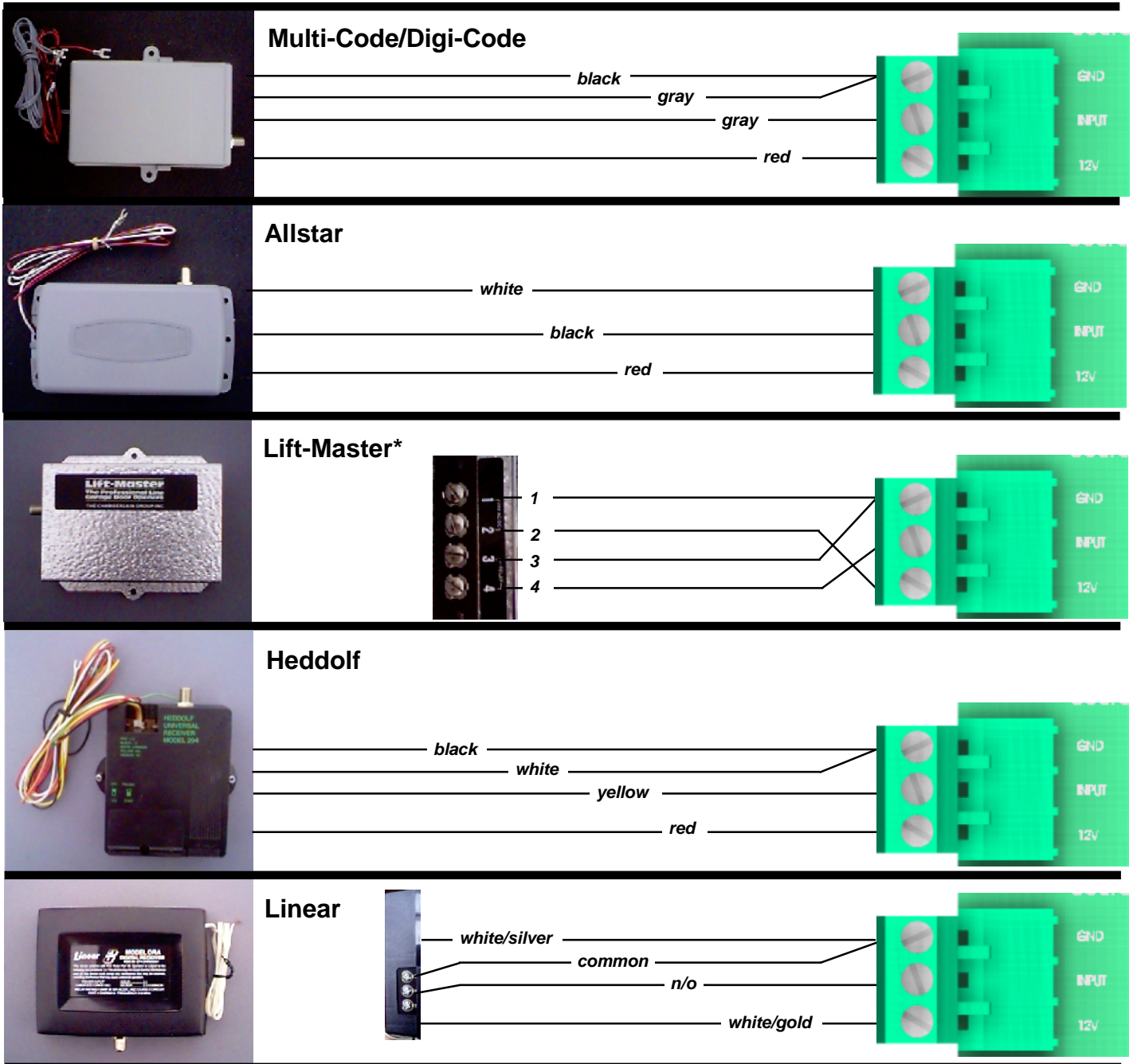


APOLLO Gate Operators RECEIVER OPTIONS

Do not confuse the receiver code switches with the red program switches on the gate control board.

Never set all code switches to the same position. Transmitters must match code switches for proper operation.

If power is taken directly from battery or connected as shown below, receiver should be configured for 12VDC



* Lift-Master will require that the 12/24 jumper be set to 12 and the C/M (constant/momentary) jumper be set to C

TROUBLESHOOTING OPERATOR & ACCESSORIES

Some troubleshooting will require a hand held multimeter. An inexpensive digital multimeter may be purchased at Radio Shack or a local electric supply company. Refer to the owners manual for instructions.

SYMPTOM *Gate opens OK but after closing, opens back up.*

1. Excessive closing pressure on gate. Re-adjust the close limit switch on the actuator.
2. Automatic reverse sensitivity is set too sensitive. Re-adjust - **CAUTION: Automatic reverse sensitivity should be set sensitive enough to avoid injury.**
3. Gate is mechanically binding. Disconnect actuator from gate and eliminate binding.
4. Battery voltage is too low. Battery voltage should be 12 to 14 volts under load. Check solar panel output or battery charger output or re-evaluate usage.
5. Replace circuit board.

SYMPTOM *Gate moves only a few feet, then stops or reverses.*

1. Battery voltage is too low. Battery voltage should be 12 to 14 volts under load. Check solar panel output or battery charger output or reevaluate usage.
2. Gate is mechanically binding. Disconnect actuator from gate and eliminate binding.
3. Actuator extension tube is bent. Inspect for damage and replace extension tube if required.
4. Current sensitivity is adjusted too sensitive. Re-adjust current sensitivity.
5. Program switch #10 is on using a non-intelligent (416E) actuator. Turn switch #10 off.
5. Replace circuit board.

SYMPTOM *Gate surges too much. Does not run smooth.*

1. Pivot arm is not ridged. Re-weld and/or brace pivot arm.
2. Bolts are loose. Snug all bolts. Pivot arm bolt should be snug but not tight.
3. Gate is too limber. Reinforce gate.

SYMPTOM *Gate will open using push button on side of box, but not with transmitter.*

1. Code switches do not match. Check that the code switches in the transmitter and the receiver match.
2. Low or dead battery in transmitter. Replace battery.
3. Fuse blown on circuit board. Check fuses on gate control board.
4. Low battery in operator. Battery voltage should be 12 to 14 volts under load.
5. Replace receiver.

Note: *Code switches for receiver are inside of receiver. Do not confuse with program switches on control board.*

SYMPTOM *Transmitter works, but not very far.*

Note: *Transmission distances will vary according to terrain, obstructions, and electrical interference. The normal range from inside a vehicle is 50-100 feet while 100-150 feet may be obtained from outside the vehicle.*

1. Low battery in transmitter. Replace battery.
2. Transmitter malfunctioning. Try a different transmitter.
3. Antenna not making good connection. Be sure center conductor of antenna is penetrating the female connector on the side of the gate box.
4. Reception is being blocked. Raise the height of the antenna using a #244 antenna extension kit.
5. Replace receiver.

SYMPTOM *Gate randomly opens, closes, or stops for no reason.*

1. Transmitter is stuck on. Check all transmitters, keypads, pushbuttons, etc. for a stuck button.
2. Transmitter and receiver code switches are all down, up, or in the middle. Change at least one switch position in the transmitter and receiver.
3. Push button on side of control box is defective. Disconnect and test.

SYMPTOM *Gate will not open or close.*

Control board in **HARD SHUT DOWN** mode.

Short the GND and UL connections on the lower left set of connectors and test.

Disconnect the solar panel or charger and measure the battery voltage. Battery should read 12 or more volts and never drop below 11 volts when gate is operating.

Reset program switches to factory settings. .

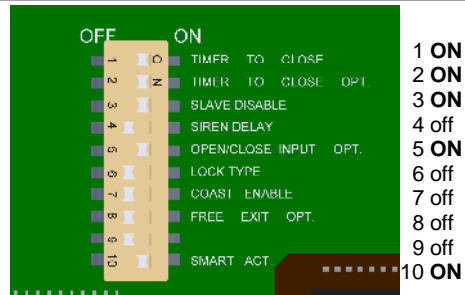
Single Boards

1, # 2, # 3, # 5, # 10 **ON**, all others **OFF**

Dual Boards

1, # 2, # 5, # 10 **ON**, all others **OFF**

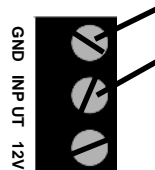
Turn #9 ON for dual gate sync



Disconnect all accessories from the circuit board - receivers, push buttons, keypads, loops, phones, intercoms, etc.

Activate the operator by momentarily shorting **GND** to **INP** on one of the three pin connectors.

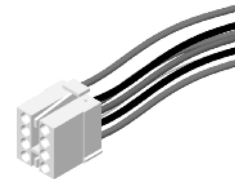
If the operator works, reconnect each accessory individually starting with push button and test operation.



Momentarily short with a piece of wire or needle nose.

Disconnect actuator from circuit board and inspect pins in the connector for damage or poor connections.

Check for proper limit switch configuration (multimeter required) on the connector from the actuator:



GATE IN OPEN POSITIONOrange & Green wires are shorted, White & Green wires are open.
 GATE IN CLOSED POSITION .. White & Green wires are shorted, Orange & Green wires are open.
 GATE IN MID TRAVEL..... White, Green, & Orange wires are open, no shorts.

Replace circuit board.



APOLLO *Gate Operators, Inc.*

LIMITED TWO-YEAR WARRANTY

Apollo Gate Operators are warranted against defects for a period of 24 months from the date of purchase, providing recommended installation procedures are followed. This warranty is in lieu of all other warranties expressed or implied (some states do not allow limitations on how long an implied warranty lasts, so this limitation may not apply to you) and shall be considered void if damage was due to improper installation or use, connection to improper power source, or if damage was caused by fire, flood, or lightning. The manufacturer will not be responsible for any labor charges incurred in the removal or replacement of defective parts.

In case of failure due to defective material or workmanship during the warranty period, the defective part will be repaired or replaced at the manufacturer's option at no charge if returned freight prepaid. New or factory rebuilt replacements may be used. Replacement parts are warranted for the remaining portion of the original warranty period. The manufacturer will pay standard ground freight on the return of repaired or replaced items in warranty.