

Nice Apollo Slide Gate Opener

8300 SL - 1/2 HP

Vehicular Slide Gate Opener

8500 SL - 1 HP



TABLE OF CONTENTS

CAUTIONS AND NOTES	2	10 - OPTIONAL INPUTS	12
EXTREMELY IMPORTANT	2	10.1 - Fire input	12
ETL DEFINITIONS COMPLIANT TO UL325	2	10.2 - Fail safe connection	12
1 - OVERVIEW	2	10.3 - Magnetic lock connection	13
1.1 - Gate controller	2	10.4 - Guard station connection	13
1.2 - Main control board	2	10.5 - Exit and edge inputs wiring diagram	13
1.3 - Main control board specifics	2	10.6 - Radio receiver connection (third party)	13
2 - GATE INFORMATION	3	11 - INSPECTION AND OPERATION	14
2.1 - ASTM F2200	3	12 - GENERAL LAYOUT AND SAFETY ACCESS	14
2.2 - Gate material	3	13 - ACCESSORIES AND SENSORS	15
2.3 - Gate latches	3	14 - BOARD NOMENCLATURE	16
2.4 - Specific applications	3	15 - PROGRAMMING BUTTONS	17
2.5 - Slide gates	3	15.1 - Force	17
2.6 - General requirements	3	15.2 - Speed	17
3 - SAFETY AND CAUTIONS	4	15.3 - Acceleration	17
3.1 - Properly installed safety devices	4	15.4 - Delay	17
3.2 - Safety signs, notices to personnel warning signs	4	15.5 - Function	17
3.3 - The gate system safety devices	4	15.6 - Display	18
3.4 - Infrared beams	4	16 - GATE DIRECTION REVERSAL	19
3.5 - Establish the location	4	17 - RE-ASSEMBLING GATE OPERATOR	19
3.6 - Read and follow all instructions	4	18 - EMERGENCY VEHICLE ACCESS	19
3.7 - Keep children away	4	19 - GLOSSARY	20
3.8 - Test the gate system	4	20 - MAINTENANCE SCHEDULE - APOLLO GATE OPENER	20
3.9 - Keep gates properly maintained	4	21 - INSTALLATION DIAGRAM	21
4 - PRE-INSTALLATION NOTES	4	22 - APOLLO GATE OPENER TROUBLESHOOTING	22
4.1 - Follow Instructions	4	23 - PROGRAMMING QUICKSTART	22
4.2 - Intended usage	4	23.1 - Learning the gate	22
4.3 - Warnings, cautions and notes	4	23.2 - Gate direction reversal	22
5 - SLIDE OPERATOR CUTAWAY DRAWINGS	6	23.3 - Putting the controller into learning mode	22
5.1 - Slide operator cutaway drawings-cont.	6	24 - INSTALLATION CHECKLIST	23
6 - INSTALLATION PROCEDURES	7		
6.1 - Step one-location	7		
6.2 - Step two-concrete	7		
6.3 - Step three-physical mounting	7		
6.4 - Step four-manual release	7		
6.5 - Step five-chain assembly	7		
6.6 - Learning and programming	7		
6.7 - How to setup for first use	7		
6.8 - The learning sequence	9		
6.9 - Learning mode	9		
7 - CIRCUIT BOARD LAYOUT	9		
8 - ACCESSORY INPUTS AND OUTPUTS	10		
8.1 - Outputs	10		
8.2 - Inputs	10		
8.3 - Communication bus	10		
8.4 - Programming the plug-in receiver and remote controls	11		
9 - WIRING AND CONNECTIONS	12		

CAUTIONS AND NOTES

This instruction manual is intended to aid the installer in the overall process of correct installation at the desired location. Periodically, the manual will illustrate “warnings, cautions and notes” which are items the installer should carefully read to prevent damage to the gate, gate system or personal injury to yourself or others.

EXTREMELY IMPORTANT

Anyone who installs, assists with installation or otherwise facilitates the installation in any manner should thoroughly read and understand this manual in its entirety before any attempt is made to actually begin the installation process.

ETL DEFINITIONS COMPLIANT TO UL325

Vehicular Slide-Gate Operator (or system) - A vehicular gate operator (or system) that controls a gate which slides in a horizontal direction that is intended for use for vehicular entrance or exit to a drive, parking lot, or the like.

- Gate - A moving barrier such as a sliding, swinging, raising, lowering, rolling, or like barrier that is a stand-alone passage barrier or is that portion of a wall or fence system that controls entrance and/or egress by persons or vehicles and completes the perimeter of a defined area.
- Residential Vehicular Gate Operator - Class I - A vehicular gate operator (or system) intended for use in a home of one to four single family dwellings, or a garage or parking area associated therewith.
- Commercial / General Access Vehicular Gate Operator - Class II - A vehicular gate operator (or system) intended for use in a commercial location or building such as a multi-family housing unit (five or more single family units), hotel, garages, retail store, or other buildings servicing the general public.
- Commercial / General Access Vehicular Gate Operator - Class III - A vehicular gate operator (or system) intended for use in an industrial location, loading dock area, or other location not intended to service the general public.
- Commercial / General Access Vehicular Gate Operator - Class IV - A vehicular gate operator (or system) intended for use in a guarded industrial location or buildings such as airport security area or other restricted access locations not servicing the general public, in which unauthorized access is prevented via supervision by security personnel.

1 - OVERVIEW

- Available in 1 and ½ HP models
- Max gate weight 1,500lbs (1hp model) and 1,000lbs (1/2hp model)
- Max gate length – 35’
- Key-lock access to the mechanical release and limit switch adjustments
- Built-in open and close limit switches and the controller’s “learn” function helps ensure a quick installation.
- Numerous inputs and outputs for accessories are available.

The new Apollo 8300SL and 8500SL gate operators line of commercial gate operator builds on the legacy of rugged, reliable ranch and residential gate controllers offered by Apollo over the last 20 years. With an endurance of over 500,000 cycles, and a working temperature range from -4°F to 150°F, these ½ and 1 horsepower systems can safely move gates up to 1,500lbs. and 35’ in length. An industrial design ensures that the Apollo 8300SL and 8500SL gate operators complement any gate installation and architecture while providing the safety features that meet or exceed UL325 and UL991 specifications.

This manual provides documentation that covers the layout, construction, mechanical and electrical installation, and programming of the Apollo 8300SL and 8500SL gate operator for a typical installation. Please consult your Apollo distributor for more information regarding installations or questions not specifically covered in this manual.

1.1 - Gate controller

The gate controller is a 120VAC powered system consisting of the main housing, the chassis, a brushed DC motor and drive sprocket, a transformer, an on-off switch, and the main control board. A key-locked manual release

and adjustable open and close limit switches are located in a weather-tight enclosure that is accessible at the top of the unit. The main control board is mounted on a tilt-up frame that is accessed by removing the front cover (non-sprocket side). An access hole is located at the bottom of the unit for connection with an electrical conduit.

1.2 - Main control board

The main control board is housed in a protective plastic enclosure that includes a 2-line LCD and with 5 dedicated buttons and 3 buttons for navigation of the setup, programming, and information menus. Connectors for power, inputs, and output peripherals are arranged around the edges of the board and clearly labeled. A plug-in connector is provided for direct installation of a Nice-brand receiver which can be controlled by up to 1000 transmitters. The O-view programmer with Bluetooth and GSM provides capability to control and manage the unit via PDA. Connectors for other Nice-brand plug in accessories include Bluetooth with GSM control for gate management via PC, PDA, or cell phone. These accessory options enable the Apollo 8300SL and 8500SL gate operator to expand its capabilities in the future as necessary without requiring any hardware changes.

Dry contact inputs are provided for loop, probe, and photoelectric detectors, as well as edge sensors, guard station, and fire department control of gate opening and closing. Voltage outputs (+12VDC and +24VDC) are also provided to power safety and entrapment-prevention devices, and a magnetic lock if required. Onboard charge control circuitry delivers reliable power to a backup battery (if installed) and the unit is equipped with input for a solar panel for self-powered installations.

The main control board 1050 can drive 12VDC or 24VDC motors and accepts DC input voltage ranging from 10VDC to 35VDC. A 2-line LCD with dedicated buttons allows the installer to quickly program the 1050 when changes to its factory-default settings need to be made. A real time clock/calendar enables programming for scheduled weekly or daily events like opening, closing, or locking the gate. Gate opening and closing speed, acceleration, soft-start settings, and reversing force may be set to factory default settings, or individually programmed per customized gate installation requirements. Built-in current sensing enables inherent gate force monitoring and limiting for safety and an onboard alarm indicates when two sequential obstructions have been sensed in either direction. The “Learn” function helps the gate installer configure the Apollo 8300SL and 8500SL gate operator semi-automatically for optimum settings of gate opening and closing speeds, with simple programmable adjustments to force and speed settings that may be made with front panel programming.

1.3 - Main control board specifics

- Inputs for solar panel and batteries.
- Low power consumption in stand-by mode.
- Built-in regulator to keep the battery charged (either thru solar or main power).
- Socket for plug-in Nice receivers (SM series).
- Board compatible with Nice Opera System (program and diagnostic also away from the site of installation).
- Easy programming with LCD display and dedicated buttons.
- Digital programming for auto-close, force, speed, opening delay.
- On board buttons for operating the gate (Open, Close, Stop).
- Built-in voltmeter to check input voltage, battery voltage, solar panel voltage, motors’ current.
- Temperature sensor to optimize charging battery and system performance.
- Programmable service alarm.
- 2 Programmable timers (from 1 sec to 9 hours).
- Inputs for guard station, additional third party receivers, loop detectors, FIRE and UL/Edge signals
- 2 programmable inputs (open, close, step, mid-position, hold to open, hold to close, activating timer).
- Surge suppression on every peripheral input (digital and analog).
- Ports for self-powered Nice plug-in peripherals. (BlueBus).
- Master/Slave bus port for wired control of a second 8300/8500 gate operator.

2 - GATE INFORMATION

2.1 - ASTM F2200

Gates shall be constructed in accordance with the provisions given for the appropriate gate type listed, refer to ASTM F2200 for additional gate types. Protrusions shall not be permitted on any gate, refer to ASTM F2200 for exceptions, if any.

Any non-automated gate that is to be automated in any manner should be upgraded to conform to the provisions contained within the provisions of this document and ASTM F2200 as applicable.

2.2 - Gate material

Gate building materials should be substantial and robust enough to sustain constant usage. This gate opener is manufactured for commercial operations primarily, and therefore the forces placed upon the gate may be in excess of those which may be applied to a residential gate operation. In many instances, tensions, forces and leverages applied in a commercial atmosphere may be in excess of those material specifications meant in residential operations. As a result of this instance, it is recommended that this gate opener never be used in conjunction with any gate system not directly intended for constant industrial or commercial operation.

2.3 - Gate latches

In association with this commercial slide gate operator, at no time should manual gate latches or locks be used. The forces applied to a commercial slide gate operator could be in excess of those forces which are safe for bystanders. Should unnecessary forces be applied to a gate system which is in the locked position, the catastrophic failure of the gate or locking mechanism could result in substantial damage, extensive physical injury and or death.

2.4 - Specific applications

This slide gate operator is intended for those locations where commercial vehicle traffic is intended to be controlled through the use of an entryway obstruction (gate). The gate system should be made of closed material types which prevent any body part from entering, becoming entangled or otherwise entering the gate in any manner. If the gate is not fully closed off from access, the opening or closing of the gate system may result in severe damage, injury or death.

2.5 - Slide gates

Slide gates are designed to slide or move horizontally across an entry control point to prevent or allow controlled access by authorized persons or equipment. Slide gate systems are not necessarily completely autonomous systems, and require regular maintenance and inspection on a periodic schedule. Although with certain safety devices in place the gate system could operate as a completely independent system free from human interaction for a defined period of time, human inspection and testing is required to ensure longevity and safe operation over long periods of time.

Install the gate operator only when all openings of a horizontal slide gate are guarded or screened from the bottom of the gate to a minimum of 4 feet (1.22 m) above the ground to prevent a 2-1/4 inch (57.2 mm) diameter sphere from passing through the openings anywhere in the gate, and in that portion of the adjacent fence that the gate covers in the open position.

2.6 - General requirements

- Safety and security are obviously a number one priority for both the manufacturer and the end user. As a result this manual has been written to make all persons fully aware of the responsibilities required to ensure constant safety, security and longevity are acquired throughout the life of the system.
- The manufacturer of this slide gate system has performed countless hours of testing, analysis and statistical control analysis to ensure that this operator performs its intended function for extended periods of time. The installer should ensure and verify that all required safety devices are installed correctly and in a manner consistent with the requirements of this manual. Additionally, all devices, security devices, safety devices, sensors and other affiliated attachments are installed in a robust manner that will prevent their accidental damage, removal or incidental tampering.
- A basic requirement for this system to operate correctly is that at any time a sensor is tripped, covered, disconnected or otherwise tampered with, that

the entire system ceases to function. If any part of the gate safety system is removed or tripped, an immediate safety action by the gate operator is expected (retraction or stoppage). If the gate safety system is not functional, or fails to operate within these guidelines, the gate should be immediately removed from service until repairs can be made.

- Any gate system that is open or has slats, bars or other material which allows an individual to stick their hands, head, feet or any other empenages through the material, must be converted or covered in such a manner so as to prevent such future actions. Application of materials, and how to modify the gate system is up to the end user or installer, however care should be taken to prevent such human interaction into the moving gate system. No entry into the gate is ever authorized and should be prevented by whatever measures are required for that specific installation. Care should always be used during installation!
- Loops and loop detectors, photo-cells or other equivalent devices must be installed with this gate operator to prevent the gate from closing on vehicular traffic.
- The speed limit for vehicular traffic through the gate area is 5 MPH. Install speed bumps and signs to keep vehicular traffic from speeding through the gate area. Failure to adhere to posted speed limits can result in damage to the gate, gate operator, and to the vehicle.
- Be sure that all residents are familiar with the proper use of the gate and gate operator. Be sure that all residents are familiar with the possible hazards associated with the gate system.
- Be sure that all warning signs are permanently installed on both sides of the gate in an area where they are fully visible to traffic.
- It is your responsibility to periodically check all reversing devices. If any of these devices are observed to function improperly, remove the operator from service immediately and contact your installing or servicing dealer.
- Follow the recommended maintenance schedule of one inspection per every 180 days of use.
- Do not allow children to play in the area of the operator or to play with any gate-operating device.
- Be sure that all activating devices are installed a minimum distance of 8 feet away from the gate and gate operator, or in such a way that a person cannot touch the gate or gate operator while using the activating device. If activating devices are installed in violation of these restrictions, immediately remove the gate operator from service and contact your installing dealer.
- To remove the gate operator from service, operate the gate to the full open position, shut off power to the operator at the service panel, and disconnect batteries.



AUTOMATIC GATES ARE NOT FOR PEDESTRIANS!



Automatic gate openers are designed for vehicular traffic. They are powerful and can cause serious bodily injury or death. Accordingly, direct all pedestrian traffic to a separate walk-through gate.

3 - SAFETY AND CAUTIONS



WARNING

IMPORTANT SAFETY INSTRUCTIONS

WARNING - TO REDUCE THE RISK OF INJURY OR DEATH:

- READ AND FOLLOW ALL INSTRUCTIONS.
- Never let children operate or play with gate controls. Keep the remote control away from children.
- Always keep people and objects away from gate. NO ONE SHOULD CROSS THE PATH OF THE MOVING GATE.
- Test the operator periodically. The gate MUST reverse on contact with a rigid object or stop or reverse when an object activates the non-contact sensors. After adjusting the force or the limit of travel, retest the gate operator. Failure to adjust and retest the gate operator properly can increase the risk of injury or death.
- Use the emergency release only when the gate is not moving.
- KEEP GATES PROPERLY MAINTAINED. Read the owner's manual. Have a qualified service person make repairs to gate hardware.
- The entrance is for vehicles only. Pedestrians must use separate entrance.
- SAVE THESE INSTRUCTIONS!

3.1 - Properly installed safety devices

Safety devices are used to sense, register and prevent damage to vehicular traffic which may block the path of the gate system. If properly installed and inspected for functionality within the prescribed maintenance procedures, the safety devices should prevent the gate system from inflicting harm or damage as a result of its opening and closing action.

3.2 - Safety signs, notices to personnel warning signs

Safety devices must alert all who may enter the gate system area, as to the danger posed by moving equipment. Safety features must be installed and working correctly, such as the infrared beam. This safety device prevents serious injury or death as a result of the gate closing while an object or person blocks the gate operating pathway. An optional flashing lamp that is activated anytime the gate is moving should be added in addition to the aforementioned safety features.

3.3 - The gate system safety devices

Great amounts of force are sometimes used to move these heavy systems. The automatic gate system may cause significant damage or injury if the path of the gate is obstructed. All sensors, safety devices and warning notices must be in place and operable in order for this system to operate properly. It is the installer's responsibility to install this system properly and to ensure its correct and safe operation.

3.4 - Infrared beams and warning signs

Infrared beams are used to inform the control board that an obstruction is present. Safety devices must be installed properly and inspected periodically to ensure continued reliability and safety. Safety devices, safety sensors, warning signs and notices of moving equipment danger must be installed and readily visible by all paths of approach to the gate system. Failure to post warnings could result in loss of life, damage or physical injury.

3.5 - Establish the location

The installer of this system needs to establish the location of the opener in accordance with instructions contained within this section. A typical layout is provided in section 12.0 with a nominal basic drawing. It is the installer's responsibility to ensure that the opener is installed in such a fashion so as to prevent binding, pinching or improper articulation of the chain drive system throughout its actuation cycle.

3.6 - Read and follow all instructions

3.7 - Keep children away

Never let children operate or play with gate controls. Keep the remote control away from children.

3.8 - Test the gate system

The gate MUST reverse on contact with a rigid object or stop when an object

activates the non-contact sensors. After adjusting the force or the limit of travel, retest the gate operator. Failure to adjust and retest the gate operator properly can increase the risk of injury or death. Test force and correct functionality for photo-eyes and other safety devices at least every 6 months. Before using the emergency release, power the system off! ONLY USE the MANUAL RELEASE when the gate is not moving or when the unit fails or in case of power outage.

- Turn the power to the gate controller OFF AND REMOVE BATTERIES before using the emergency release. The ON/OFF switch for the gate operator is located adjacent to the main controller board.

3.9 - Keep gates properly maintained

Read the owner's manual. Have only a qualified service person make repairs. Unqualified service technicians are not recommended.

4 - PRE-INSTALLATION NOTES

Before installing and operating the unit, installers should:

- Confirm the gate operator being installed is appropriate for the application.
- Confirm the gate is designed and built according to current applicable published industry standards.
- Confirm all appropriate features and accessory devices are being incorporated, including both primary and secondary entrapment protection devices.
- Make sure the gate works freely before installing the operator.
- Repair or service worn or damaged gate hardware before installing the operator.
- Adjust the load-sensing device to the minimum force setting that allows reliable gate operation.
- Install operator inside fence line (DO NOT install operator on public side of fence line).
- Install a proper electrical ground to a gate operator.
- Install keypad controls where users cannot touch, or reach through gate while operating controls.
- Install controls where user has full view of gate operation.
- A minimum of two (2) WARNING SIGNS shall be installed, one on each side of the gate where easily visible.
- Test all features for proper functions before placing the automatic vehicular gate into service.
- Demonstrate the basic functions and safety features of the gate system to owners/end users/general contractors, including how to turn off power and how to operate the manual disconnect feature.
- Leave safety instructions, product literature, installation manual and maintenance manual with end user.
- Explain to the owners the importance of a service contract that includes a routine testing of the entire system including the entrapment protection devices, and explain the need for the owners to insure that this testing is performed routinely.
- Offer the owner/end user a maintenance contract, or contact them regularly to offer maintenance.
- This system is designed specifically for commercial applications but may be used on residential applications where needed.
- See instructions on the placement of non-contact sensors for each type of application.

4.1 - Follow Instructions

Always follow all instructions included in this manual to ensure safety and the longevity of the operator.

4.2 - Intended usage

THIS GATE SYSTEM IS INTENDED FOR USE WITH VEHICULAR SLIDE GATES ONLY.

4.3 - Warnings, cautions and notes

- 4.3.1 Gate system designers, installers and users must take into consideration the inherent hazards associated with each installation, since no two installations will be exactly like another.
- 4.3.2 Improperly designed, constructed, installed or maintained systems can and may introduce hazards which may or may not be readily seen or identified by users, bystanders, installers or inspectors.
- 4.3.3 All pinch points must be guarded or eliminated.

- 4.3.4 Only install this gate system opener in appropriate manners in which the operation is safe and secure.
- 4.3.5 A gate operator exerts a great amount of force in order to move the gate system in normal operation, therefore appropriate safety sensors, measures, notices and appropriate safety features must be incorporated in all installations.
- 4.3.6 The gate must be installed correctly and no binding or resistance should be present throughout its movement in either direction.
- 4.3.7 The gate system must be installed in an area and in such a manner in which the gate has sufficient clearance to open, close and move without striking or contacting any structures and/or other obstructions.
- 4.3.8 The gate system is designed for vehicular traffic only, and should never, under any situation be used for pedestrian traffic.
- 4.3.9 Pedestrian prohibited signs, warning signs or other suitable measures must be used at minimum, to warn pedestrians to stay away from, and to not use this system under any circumstances.
- 4.3.10 Pedestrians should be encouraged to use a pedestrian entry/exit only.
- 4.3.11 Pedestrians should never cross the path of a moving gate. The sensors are designed to prevent contact with a vehicle and are not necessarily capable of preventing contact with a pedestrian. Care should be taken to prevent pedestrian usage under any circumstances.
- 4.3.12 One or more non-contact sensors must be used in any situation or area where entrapment may have the possibility of occurring.
- 4.3.13 Gates shall be constructed in accordance with the provisions given for the appropriate gate type listed, refer to ASTM F2200 for additional gate types.
- 4.3.14 Any existing manual gate latches shall be removed or disabled when an automatic gate system is installed. Use only mag-locks controlled by the system.
- 4.3.15 Protrusions shall not be permitted on any gate, refer to ASTM F2200 for exceptions, if any.
- 4.3.16 Gates shall not be designed, constructed and installed in such a manner that gravity will cause or initiate movement in any direction whether the operator is attached or not.
- 4.3.17 A pedestrian gate shall not, under any circumstances, be attached to, or incorporated into, any vehicular gate system in manner. This also applies to any fence or wall, or any portion thereof, that the gate may cover in the open or closed position.
- 4.3.18 Any non-automated gate that is to be automated in any manner should be upgraded to conform to the provisions contained within the provisions of this document and ASTM F2200 as applicable.
- 4.3.19 To reduce the risk of severe injury or death please read and understand this entire manual and your local code requirements prior to starting installation. Additionally, understanding the ASTM standards will assist you in the proper assembly, installation and operation of your gate opening system.
- 4.3.20 Disconnect all electricity and/or all sources of power before performing any maintenance.
- 4.3.21 To reduce the risks of fire or injury always contact the installer or distributor prior to performing any repairs or maintenance.
- 4.3.22 Never operate gate with obstructions present.
- 4.3.23 No one should ever cross the operative path of the gate.
- 4.3.24 Never let children play or linger in the vicinity of the gate or opener equipment.
- 4.3.25 Never operate the gate or the opener when the opener is not operating or adjusted correctly.
- 4.3.26 Never allow children to play with or manipulate gate controls. Keep all remotes away from children.
- 4.3.27 Only use the MANUAL RELEASE when gate is completely stationary. Untrained persons should never touch the gate or any releases if any are installed or applicable.
- 4.3.28 Test the gate operator periodically (once every 6 months minimum). Gate must reverse course or stop immediately upon contact with any source in its path. Gate must stop and reverse course at any time any object or other item crosses the path of the gate. Should the safety sensors not stop and/or reverse the gates travel, immediately investigate and repair the inoperative condition. Gate should not be used under any circumstances, if all sensors and safety devices are not performing to standards illustrated within this manual.
- 4.3.29 Gate should not be used if safety devices are not performing to all local, state and federal guidelines.
- 4.3.30 Replace fuse only with fuse of same type and rating.
- 4.3.31 Installation of this gate operator in a manner inconsistent with the manufacturer's recommended instructions, local, State or Federal law transfers the liability unto the installer. Careful consideration has been taken by the manufacturer to devise safe measures, safe design and incorporate safety measures to prevent injury, death or property damage. By circumventing, ignoring or modifying any safety system or the exclusion thereof, the installer is creating a new untested process outside the purview of the manufacturer and therefore assumes all risk.
- 4.3.32 This unit is not to be installed on any gate, door or other structure which serves to block, secure, close off or otherwise control a pedestrian entry point or access point.
- 4.3.33 Vehicular slide gates shall be designed, constructed and installed in accordance with security related parameters specific to the application in question, with absolute safety in all considerations.
- 4.3.34 Never mount any device that operates the gate opener where the user can reach around, over or through the gate to operate the controls. Controls should be mounted at minimum, 8 feet away from any moving part of the gate or gate system.
- 4.3.35 A hard wired control shall be located in such a manner so that electronic communication between the two is never interrupted or the wires damaged.
- 4.3.36 Any controls used to reset the device after obstruction/entrapment protection incidents should be located within view of the gate and should have safety features that prevent unauthorized use.
- 4.3.37 Never allow anyone to ride, hang on or otherwise touch the gate.
- 4.3.38 Safety sensors must be present at all times. The hard wired safety sensors must be arranged and installed in such a manner so that the communication between gate operator and sensor(s) are never interrupted or severed by mechanical damage or movement. All items which have sensors or safety devices installed must be constructed or installed in such a manner so as to prevent removal or damage. All subsequent sensors must be suitable for the system installed and approved for use.
- 4.3.39 Never increase the force used to move the gate, beyond the absolute minimum required.
- 4.3.40 Never use force adjustments to compensate for binding, sticking or resistant operation. These situations should be addressed and corrected before installation of the gate operator. Gate systems should slide freely in all directions prior to installation of this gate operator.
- 4.3.41 After any adjustment is made, all safety modes/features must be tested. Gate must stop or reverse upon any object crossing the path of the gate or the gate comes into contact with any object.
- 4.3.42 Activate gate only when the gate is in clear view of the user, the gate system is properly adjusted, tested and verified, and there are no obstructions present.
- 4.3.43 Keep gate and gate system properly maintained and properly inspected at all times.
- 4.3.44 This operator is intended for installation only on slide gates used to control vehicular traffic.
- 4.3.45 The gate must be installed in a location so that sufficient clearance is provided between the gate and adjacent structures when opening and closing to reduce the risk of entrapment.
- 4.3.46 The gate must be properly installed and work freely in both directions prior to the installation of the gate operator.
- 4.3.47 Install the gate operator only when the operator is appropriate for the construction and the usage class of the gate.
- 4.3.48 The gate must be properly installed and work freely in both directions prior to the installation of the gate operator.
- 4.3.49 Controls must be far enough from the gate so that the user is prevented from coming in contact with the gate while operating the controls. Controls intended to be used to reset an operator after two sequential activations of the entrapment protection device(s) must be located in the line of sight of the outdoor gate or easily accessible controls shall have a security feature to prevent unauthorized use.
- 4.3.50 All warning signs and placards must be installed where visible in the area of the gate.
- 4.3.51 Care shall be given to reduce the risk of nuisance tripping such as when a vehicle trips the sensor while the gate is still moving.
- 4.3.52 Gate operators must utilize a contact sensor such as an edge sensor.
- 4.3.53 A hardwired contact sensor shall be located and its wiring arranged so that the communication between the sensor and the gate operator is not subject to mechanical damage.
- 4.3.54 A wireless contact sensor such as one that transmits radio frequency (RF) signals to the gate operator for entrapment protection functions are recommended.

5 - SLIDE OPERATOR CUTAWAY DRAWINGS

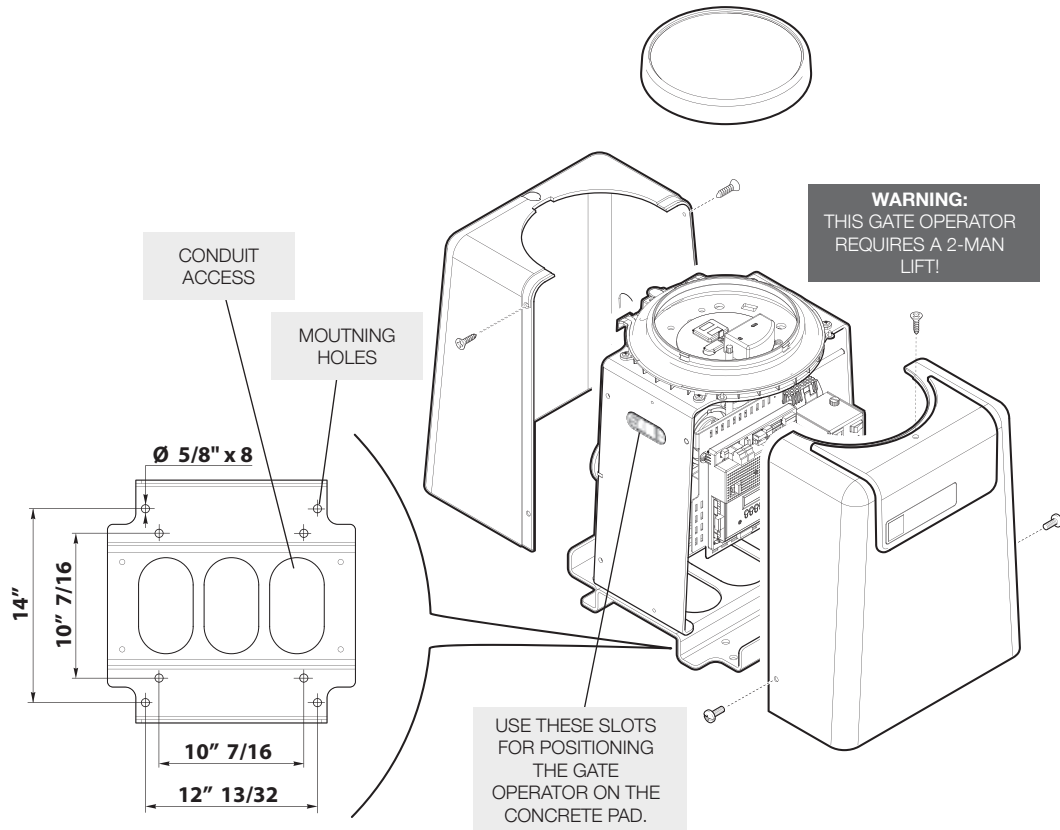

Figure 1 - SLIDE OPERATOR CUT-AWAY

5.1 - Slide operator cutaway drawings-cont.

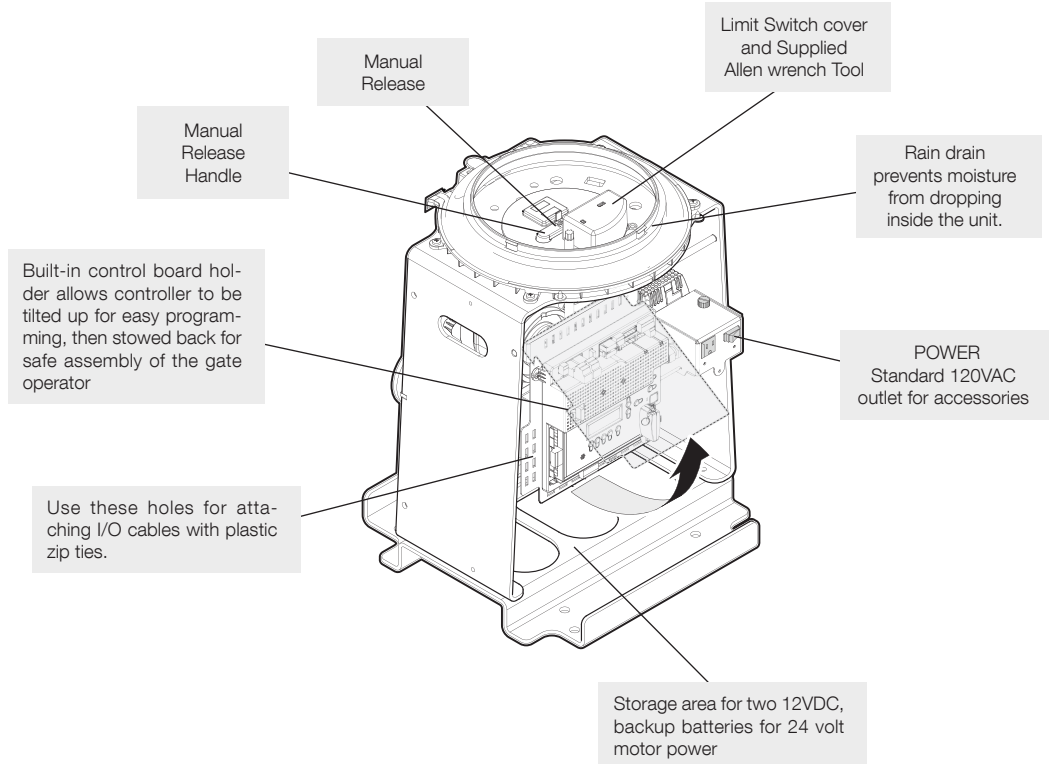
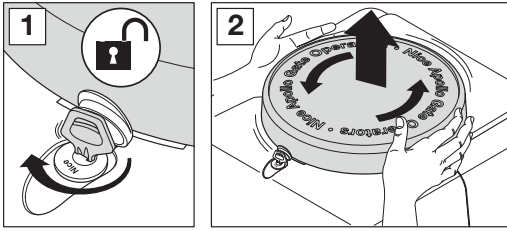

Figure 2 - OVERALL LAYOUT

6 - INSTALLATION PROCEDURES

1. Remove top cover assembly by unlocking the lid with the supplied key.

2. Turn lid counter-clockwise then remove.



Remove side bolts and covers to access interior for installation.

Remove gate operator cover screws according to the numbered sequence as shown.

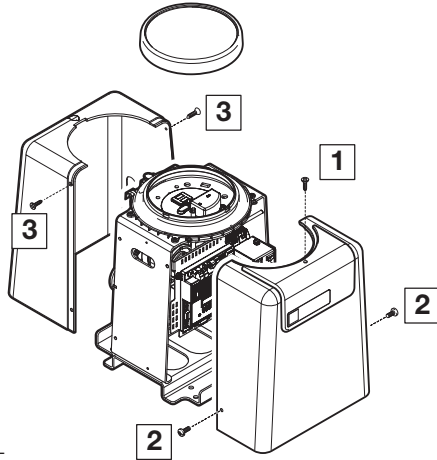

Figure 3 - COVER REMOVAL

6.1 - Step one-location

Locate the area in which the opener shall be located.

6.2 - Step two-concrete

Fabricate a concrete pad structure sufficient to stabilize and mount the gate opener. Please consult the local building dept. and/or a structural engineer to build a concrete pad that meets building codes and is sufficient for the soil type and climate and capable of supporting the lateral loads imposed by the operator during operation. See figure 4 for proper installation.

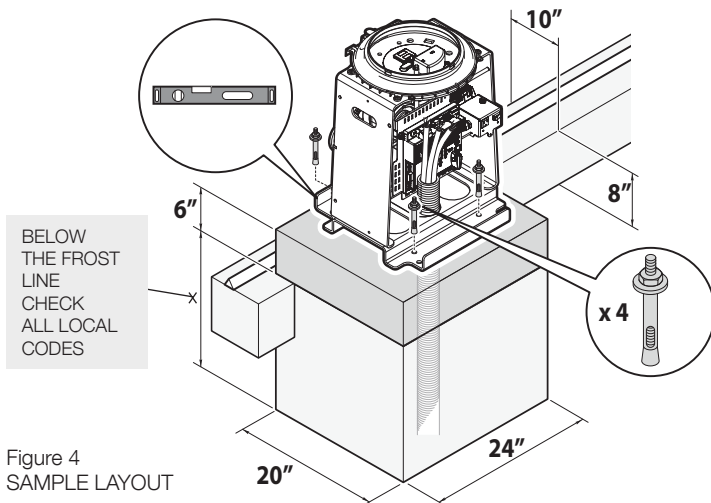

Figure 4
SAMPLE LAYOUT

6.3 - Step three-physical mounting

Drill and insert Redhead (1/2" x 3 1/3") concrete anchors into the concrete sufficient to properly mount the gate opener. Mounting position must be a minimum distance of 4 inches distance between the gate and center chain drive sprocket. (Refer to figure 29) Open the top cover using the supplied key (Refer to figure 3.). Remove the top and side covers to gain access to mounting holes. Set the unit in place and attach wiring as indicated in the wiring section 9.0 Wiring and Connections of this manual.

MAKE SURE ALL POWER IS DISCONNECTED PRIOR TO ANY SERVICE OR INSTALLATION.

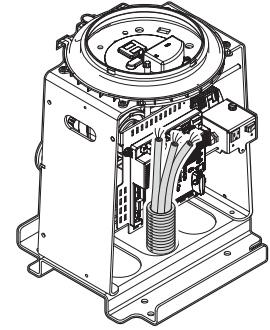

Figure 5 - WIRING

6.4 - Step four-manual release

Locate the manual release handle. Turn the manual release handle counter-clockwise until the handle stops. The chain drive assembly is now disengaged and the gate may be operated by hand.

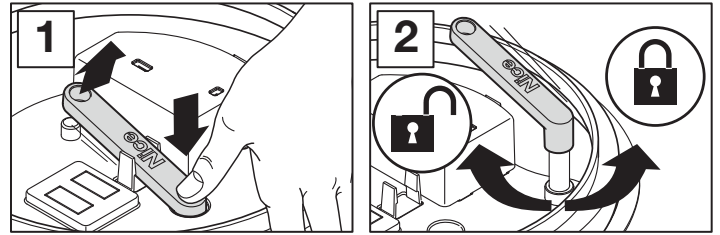

Figure 6 - MANUAL RELEASE

6.5 - Step five-chain assembly

Connect Chain assembly to sprocket assembly and test gate for free movement. (Should move freely in both directions) Push the gate by hand to the full movement in each direction to ensure it does not bind or catch in any manner. (Refer to figures 29 and 30 for diagrams of correct and incorrect installation).

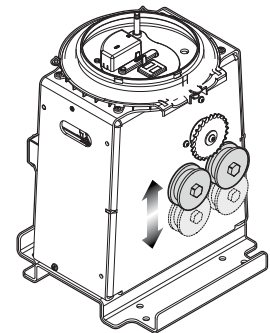

Figure 7 - BRACKET

6.6 - Learning and programming

These steps begin the basic "Learning" programming of the gate opener unit. Most all of the features and programming are pre-set and already set up for most standard installations. The installer most often will only be required to plug the unit into electrical power, connect the chain to the sprocket assembly and by setting the limits on the gate movement, and then "learning" the unit. In most cases this is the extent of the basic programming procedure. If the unit is not in LEARNING MODE see section 6.9 to place the unit into this mode. Apollo has taken great care to simplify the installation, operation and safety of this device and to ensure longevity and reliability of the unit over time. The learning procedure consists of the following steps.

6.7 - How to setup for first use

1. Install electrical power connections to the gate opener unit. Ensure the power switch is in the OFF position prior to touching any of the power connections. Install all gate accessories such as Photo-Eye's, Sensors, Loops and other safety devices.

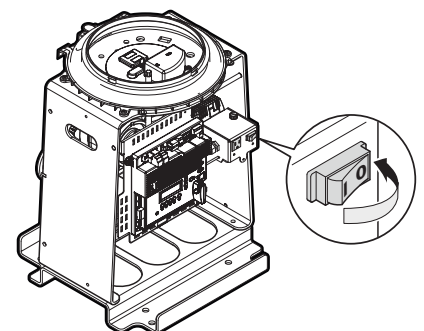

Figure 8 - SETTING UP POWER

- Using the MANUAL RELEASE HANDLE, Move it counter-clockwise to disengage the drive motor. Ensure that the gate moves freely by moving it manually to the full extents of its travel in both directions verifying there is no binding or cause for resistance.
- Using the MANUAL RELEASE HANDLE, move it clockwise to re-engage the drive system and then stow the handle.

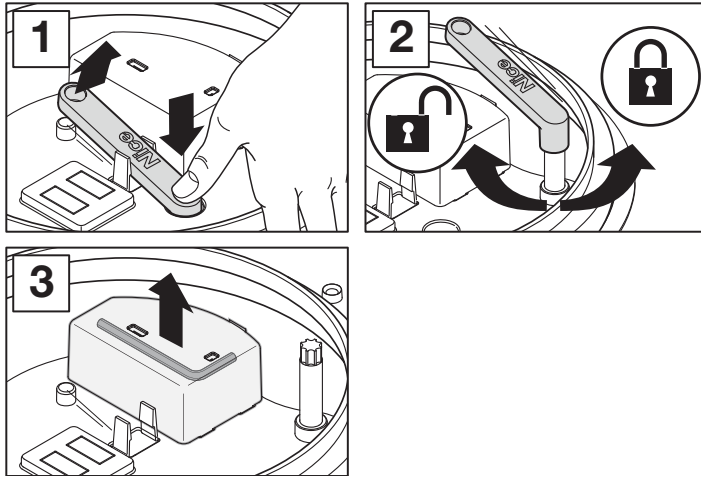

Figure 9 - MANUAL RELEASE

- Remove the Allen key inside the lid (phase 3 - fig. 9) and then loosen the grub screw of the cams (phase 4 - fig. 11) so that they can be turned freely by hand.
- Turn on the electrical power to the unit.
- Using the OPEN button on the front of the Control board, hold the OPEN button down until the gate reaches the fully open position or where the installer wants the gate to stop as FULLY OPEN (see figure 11). If the gate moves the wrong direction, refer to section 16.0 to reverse the direction.
- Once the gate is in the position where the gate is intended to be "FULLY OPEN" the OPEN limit switch must be adjusted to inform the circuit board that the gate is in the correct position to STOP at that position in the future.

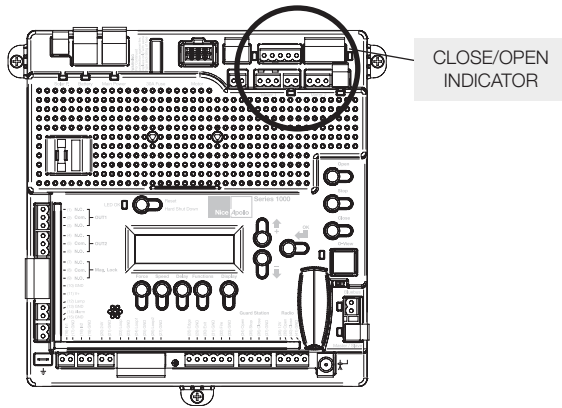

Figure 10 - INDICATOR LIGHT

To adjust the OPEN limit switch on the LOWER CAM (see figure 11) and adjust that Open Limit Switch CAM until the GREEN light (see figure 10) illuminates on the front of the control board. The FULLY OPEN limit switch is now set. Holding it firmly in place, use the supplied allen wrench to tighten the set screw.

- Using the CLOSE button on the front of the Control Board, hold the CLOSE button down until the gate reaches the fully intended closed position. Once the gate is in the FULLY INTENDED CLOSED position on the UPPER CAM (see figure 12) and adjust the CLOSED Limit Switch CAM until the RED light illuminates on the front of the control board. The FULLY CLOSED limit switch is now set. Holding it firmly in place, use the supplied allen wrench to tighten the set screw.
- During the course of initial setup, a fine adjustment of the limit switch may be required. Each limit switch CAM has a fine adjustment screw built in to allow the installer to make very small incremental adjustments to ensure the gate reaches the exact position desired. This feature is used after operating

the gate to fine tune the exact stopping point. See step 7 in Figure 11 and Figure 12.

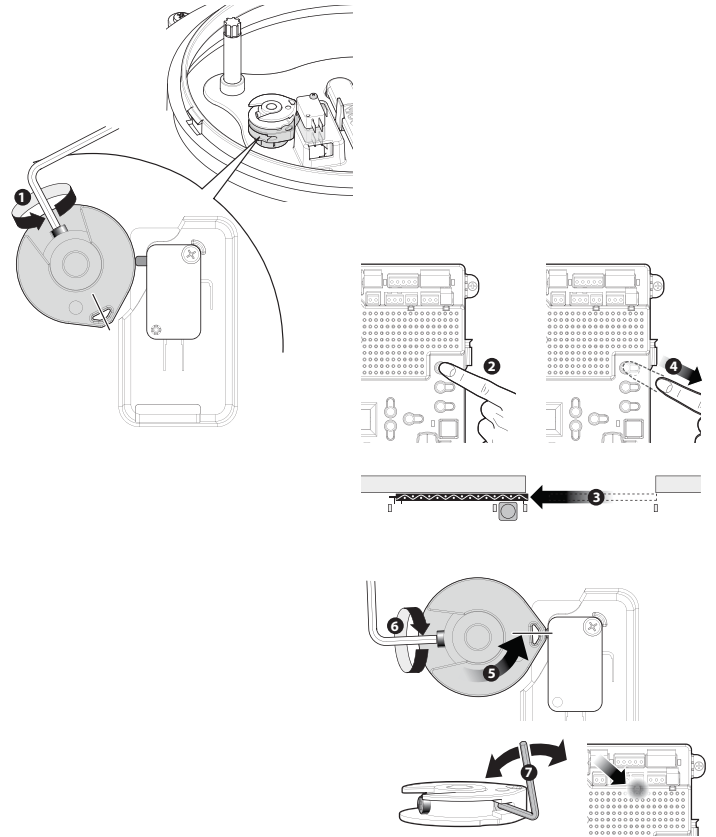

Figure 11 - FULLY OPEN LIMIT SWITCH

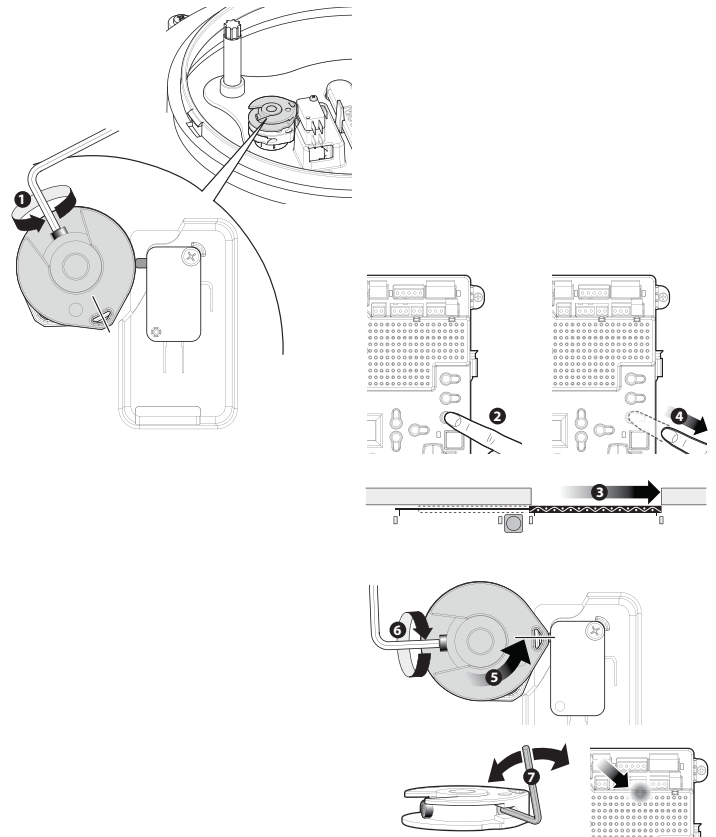

Figure 12 - FULLY CLOSED LIMIT SWITCH

6.8 - The learning sequence

Once the limit switches are all set, the final step is to LEARN the control board. To perform this task, follow the below listed steps:

1. The control board is already in the "LEARNING MODE" when shipped. In any case follow steps of section 6.9 in order to select the most appropriate kind of gate according to the installation. Press "OK" to allow the control board to scan for attached items, such as sensors, photo-eye's and other safety devices.
2. The gate will open partially, then stop. This is being done, so that the control board can sense the type and operational condition of the drive motor. The gate will then run to the closing limit, so that it can properly sense where it is located.
3. The control board will then OPEN the gate slowly to establish travel and limits.
4. Once the gate reaches the fully OPENED limit switch, the control board will now increase gate travel speed to the highest speed allotted, and will now travel to the fully CLOSED position at full speed.
5. The gate opener is now programmed for basic usage.

6.9 - Learning mode

If not in learning mode, follow the below listed steps;
Steps on how to place the Apollo 1050 control board into learning mode.

1. Press Function
2. Press OK
3. Select Slide
4. Select weight of gate
5. Press Enter

Unit should now be in LEARNING MODE.

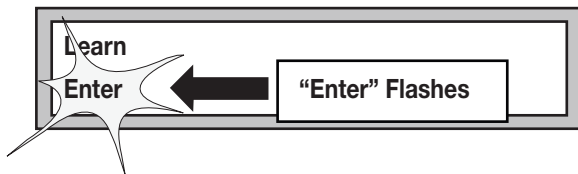

Figure 13 - LCD DISPLAY

7 - CIRCUIT BOARD LAYOUT

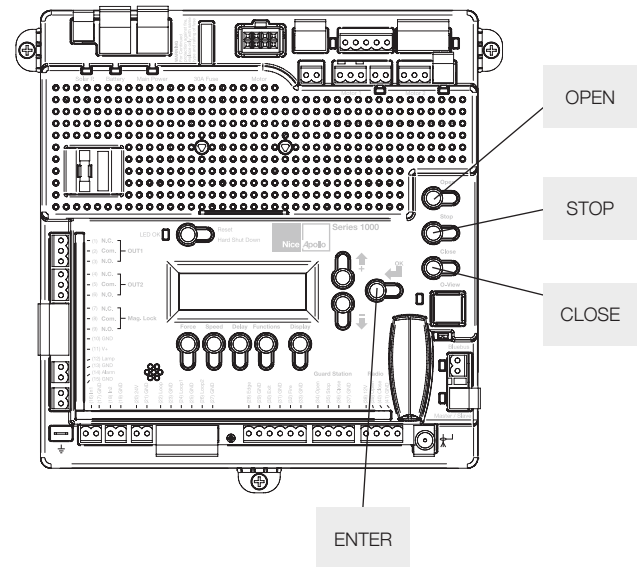

Figure 14 - CONTROL BOARD BUTTONS

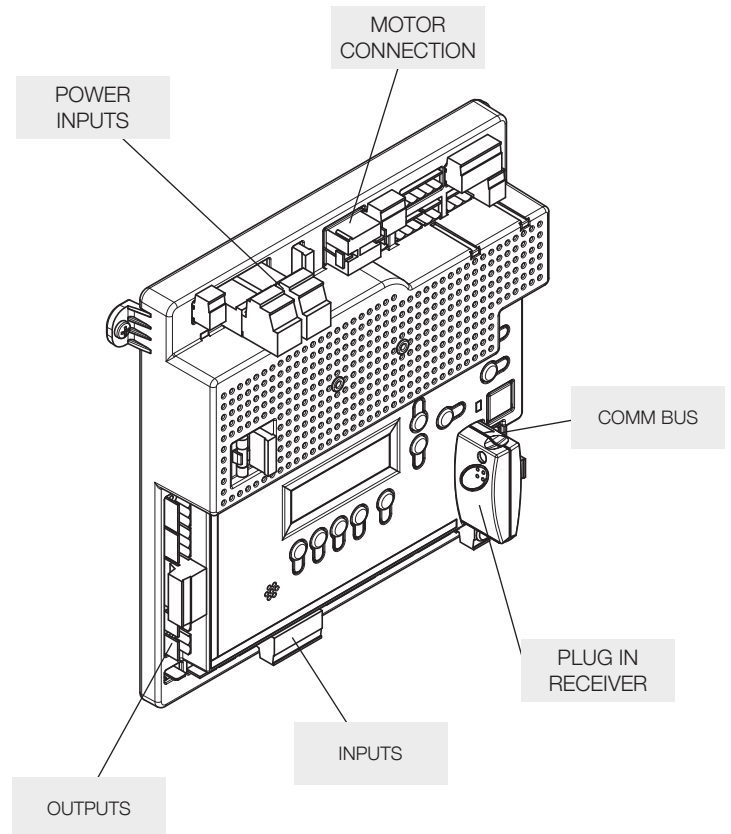

Figure 15 - CIRCUIT BOARD LAYOUT

8 - ACCESSORY INPUTS AND OUTPUTS

8.1 - Outputs

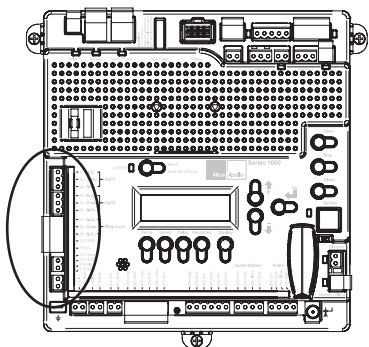

Figure 16 - BOARD OUTPUTS

Commercial Gate Operator Accessory Outputs:

OUT1 and OUT2: Individual, isolated relays provide COMMON, NORMALLY OPEN, and NORMALLY CLOSED dry contacts (35V 5A max) for switching accessories based on programming of the "Auxiliary IO" function. These outputs are programmed in the "FUNCTION Auxiliary I/O" menu.

Magnetic Lock: Provides fused power (1.85A max) and isolated relay COMMON, NORMALLY OPEN, and NORMALLY CLOSED dry contacts (35V 5A max) for electrically powered and maintained magnetic locks. The delay for magnetic lock activation/deactivation may be adjusted from 0 to 5 seconds.

Lamp: Provides fused power (1.85A max) to drive a flashing warning lamp to indicate gate operation. This output is active when the gate is operating (Opening and Closing). Sets the amount of time the lamp accessory output is activated prior to gate movement. Settings from 0 to 5 seconds with a step of 0.5 seconds.

Alarm: Provides fused power (0.5A @ 12VDC) to drive an alarm siren to signal the occurrence of a hard shutdown, caused by 2 consecutive entrapment events (signals). This alarm output is reset by pressing the "Reset Hard Shutdown" button on the front panel or activating the "FIRE" input.

8.2 - Inputs

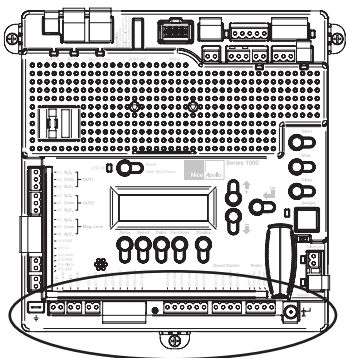

Figure 17 - INPUTS

Commercial Gate Operator Accessory Inputs:

Auxiliary Inputs 1 (16) and 2 (18): These digital inputs may be connected to the digital outputs of accessories and programmed to activate or control the gate operator in a number of different modes. Shorting pin 1 to pin 2 through a dry contact activates the programmed settings for these input. These inputs are programmed in the "FUNCTION Auxiliary I/O" menu.

LOOP Input: (22) Dry contact input that can be programmed for an inductive safety loop or photo-eye detector. Shorting the digital input to GND reverses a closing gate to the full open position. The opened gate is held opened for as long as the LOOP input is active.

LOOP 1 Input: (24) Dry contact input that can be programmed for an inductive safety loop or photo-eye detector. Activating the LOOP 1 input maintains an OPEN gate fully open and a CLOSED gate fully closed until deactivated.

Setting the LOOP1 input to "Photo Mode" causes the moving gate to stop, then reopens the gate when the LOOP1 input is deactivated.

LOOP 2 Input: (26) Dry contact input that can be programmed for an inductive safety loop or photo-eye detector. Activating the LOOP2 input (26) closes the gate to the fully closed position. This loop input is intended for use with safety sensors to prevent entrapment between the opening gate and an adjacent wall or structure.

Edge Input: (28) This input may be configured as "DIGITAL" or "ANALOG" as required by the sensor type. When configured as "DIGITAL", this is a dry contact input; otherwise when configured as "ANALOG", the input must measure 820ohms. When the input is activated it stops the gate regardless of direction of travel, momentarily reverses it then stops.

Exit Input: (30) Dry contact input for a vehicle exit sensor. Opens gate from the closed position and holds gate open with maintained input or reverses gate if closing.

Fire Input: (32) Dry contact input for a fire department control switch. Opens the gate and holds the gate open until the control switch is deactivated. Auto-close is disabled when this input is activated. Also clears hard shutdown.

GUARD STATION

Guard Station Open: (34) Dry contact input for a guard station open switch. Momentarily shorting the digital input to GND opens the gate (master and slave) to the full open position with the subsequent auto-close feature enabled.

Guard Station Stop: (35) Dry contact input (Normally Closed) for a guard station stop switch. Momentarily opening this input stops the opening gate at its current position. While this input is activated, all other inputs are disabled and are not functional.

Guard Station Close: (36) Dry contact input for a guard station close switch. Momentarily shorting the digital input to GND closes the gate (master and slave).

RADIO

Radio Open: (39) Dry contact input for an accessory radio open switch. Momentarily shorting the digital input to GND opens the gate to the full open position with the subsequent auto-close feature enabled.

Radio Close: (40) Dry contact input for an accessory radio close switch. Momentarily shorting the digital input to GND closes the gate.

Radio Input: Open/Close: (39 and 40) If you tie open and close together the unit will operate like a garage door opener in the instance that each time you press the button, it will either OPEN, STOP or CLOSE.

8.3 - Communication bus

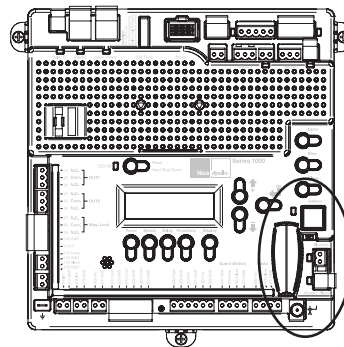

Figure 18 - COMMUNICATION BUS

OVIEW

Programming and diagnostic unit which connects directly to the gate controller and is part of the Nice "Opera" control system. The unit can be used in "stand-alone" mode via its front-panel keypad, or it may be accessed via a Bluetooth or cellular-enabled PDA, PC, or Smartphone when used with the

O-View Software Suite. This unit, when matched with the OVIEW Bluetooth or GSM modules, enables remote control and management of the gate controller. Remote control functions include all programming functions that are available at the front panel LCD on the control board as well as software updates.

OVBT: Bluetooth module for OVIEW and the "O-View Software Suite" application for PC, PDA, or Smartphone for localized wireless control of the gate controller.

OVBTGSM: GSM module that plugs into the OVIEW and provides cellular phone access through the "O-View Software Suite" application for PC, PDA, or Smartphone, for wireless local, national, and international controller of the gate controller.

O-VIEW Software Suite: Provides desktop or Smartphone level control of the gate controller. Other benefits include software updates that can be made wirelessly as new versions of software are made available.

BLUEBUS ACCESSORIES

MOTB: Moon Touch programmable keypad with secure codes (up to 9 digits per code if required) to control gate opening and closing. Connects to the 2-wire BlueBUS connector with inexpensive unshielded twisted-pair wire.

MOMB: Proximity card access control with capacity for up to 255 MOCARD or MOCARDP transponder cards. Connects to the 2-wire BlueBUS connector with inexpensive unshielded twisted-pair wire.

FT210B: Photocell transmitter and receiver pair that connects to the 2-wire BlueBUS connector with inexpensive unshielded twisted-pair wire and is a non-contact sensor for entrapment protection as specified in UL325, Section 31.1 "General Entrapment Protection Provisions".

MASTER/SLAVE

The gate operator includes a two-pin connector designed to link two separate gate operators together as a Master/Slave pair. The Master/Slave configuration is enabled by connecting two gate operators with simple, unshielded twisted-pair wire (Max. 100 ft.). All entrapment sensors, switch inputs, receiver controls, and outputs must be wired to the gate operator designated as the "Master". The following procedure outlines the process for configuring the Master/Slave pair.

Perform the "Learn" process to configure open and close limits with the gate for each operator. See the "Programming Quick Start" procedures in this manual for a description of the gate learning process.

On the Master operator, select Function -> Adv. Settings -> Remote Mst. Slv. Then select On -> Master. The red LED associated with the Master/Slave connector will illuminate.

On the Slave operator, select Function -> Adv. Settings -> Remote Mst. Slv. Then select On -> Slave. The red LED associated with the Master/Slave connector will illuminate.

The Master/Slave pair is now configured. The Slave gate operator will perform identical open/close/stop functions in tandem with the Master gate operator.

8.4 - Programming the plug-in receiver and remote controls

SMXI/A Plugin Receiver: The SMXI/A 433Plug-In Receiver provides up to 15 channels for specific control of individual gate functions. The receiver includes built-in programming functions for adding or removing Nice FloR/A wireless remote controls to/from a gate installation. The following procedures detail the steps to assign a remote control, add a new remote control, delete a single remote control, or remove all remote controls from the receiver memory.

Programming the FloR/A 2-Button or 4-Button Remote Control with the SMXI/A Plug-In Receiver.

These procedures apply to the FloR/A wireless remote control. These procedures assign factory default controls automatically to the remote control.

1. Have a functioning Nice FloR/A 2-button or 4-button remote control with a battery installed prior to programming the remote control.
2. Press and hold the button on the side of the SMXI/A receiver until the led illuminates green on the SMXI/A receiver, then release the button.
3. Within 10 seconds, press and hold any key on the FloR/A remote control until the led in the SMXI/A receiver blinks green 3 times, indicating that the FloR/A is programmed to control the receiver.
4. After the led on the SMXI/A receiver blinks green 3 times, another 10 second interval is started to program another FloR/A remote control if desired.

Repeat step 3 to program the additional FloR/A remote control. Step 3 may be repeated as many times as necessary to program all available FloR/A remote controls.

5. Verify that the FloR/A remote control(s) can control the gate by pressing one or more buttons individually on the remote control(s).

Wirelessly add new remote control to the SMXI/A Plug-In Receiver

A FloR/A remote control that has been programmed to control a SMXI/A receiver may be used to create other FloR/A remote controls for the same receiver. This procedure needs to be performed within 10 to 20m (30 to 60 feet) of the SMXI/A receiver, but the SMXI/A receiver does not need to be physically accessed.

1. Press and hold any button on the un-programmed FloR/A remote control for at least 5 seconds, then release the button, taking note of the button that was pressed.
2. Press the same button on the programmed FloR/A remote control three times.
3. Press the same button in step 1 on the un-programmed FloR/A remote control and release.
4. It is recommended to test the new copy of the FloR/A remote control with the assigned gate controller.

NOTE: This procedure will affect all SMXI/A receivers within radio range.

Deleting a Single FloR/A Remote Control from the SMXI/A Plug-In Receiver Memory

A FloR/A remote control that has been programmed to control a SMXI/A receiver may be removed from the SMXI/A receiver memory without affecting other assigned remote controls. This procedure needs to be performed at the SMXI/A Plug-In Receiver with the affected FloR/A remote control.

1. Press and hold the button on the side of the SMXI/A receiver until the led on the SMXI/A receiver illuminates green and keep the button pressed. The led will illuminate after approximately 4 seconds.
2. Press and hold any button on the FloR/A remote control until the led on the SMXI/A receiver blinks 5 green flashes.
3. Release the button on the side of the SMXI/A receiver.
4. It is recommended to verify that the de-programmed FloR/A remote control no longer controls the gate.

Deleting All FloR/A Remote Controls from the SMXI/A Plug-In Receiver Memory.

All programmed remote controls may be removed from the SMXI/A plug in receiver memory. This procedures need to be performed at the gate controller.

1. Press and hold the button on the side of the SMXI/A receiver until the led on the SMXI/A receiver illuminates green and keep the button pressed.
2. Watch the led and on the receiver and verify the following sequence in the led.
3. Within 4 seconds after pressing the button (approx.) the green led illuminates.
4. Within 8 seconds after pressing the button (approx.) the green led turns off.
5. With 12 second after pressing the button (approx.) the green led starts flashing.
6. Count the green led flashes on the SMXI/A receiver. On EXACTLY the 5TH flash, release the button on the SMXI/A receiver.
7. It is recommended to test the FloR/A remote controls, if available, with SMXI/A plug in receiver to verify that it no longer affects the gate controller.

9 - WIRING AND CONNECTIONS

Permanent wiring is to be employed for the installation as required by local codes.

Use only U.L. listed (or equivalent) non-contact sensors. Inputs from the photo-beam to the circuit board are Normally Open (N.O.). Use only U.L. listed (or equivalent) non-contact sensors.

Connect the non-contact sensors. Inputs from the photo-beam to the circuit board are Normally Open (N.O.). Photo-beam input shall REVERSE travel of gate when activated during the CLOSE CYCLE ONLY. Gate will resume normal operation when photo-beam is no longer activated.

To reduce the risk of SEVERE INJURY or DEATH;

- Disconnect power to the gate operator by manually opening its dedicated circuit breaker before making any mechanical or electrical adjustments.
- Use a 20 Amp dedicated circuit breaker for each installed gate operator
- Open dedicated circuit breaker supplying power to this gate operator BEFORE a new installation or making any modifications to an existing installation of this gate operator.
- All wiring connections MUST be made by a qualified individual.
- Run individual circuits in separate U.L. listed conduits. Do not combine high voltage (120VAC) power wiring and low voltage (+12VDC to +24VDC) control wiring in the same conduits.
- It is highly recommended that a grounding rod be installed with each operator according to local building codes to provide protection against near lightning strikes. Contact local underground utility companies BEFORE digging.
- Use the information in table 1 to determine high voltage wire size requirements. The distance shown in the chart is measured in feet from the operator to the power source. If power wiring is greater than the maximum distance shown, it is recommended that a service feeder be installed. When large gauge wire is used, a separate junction box must be installed for the operator connection. The wire table is based on stranded copper wire. Wire run calculations are based on a 110 VAC power source with a 3% voltage drop on the power line, plus an additional 10% reduction in distance to allow for other losses in the system.

Table 1 - Wire Gauges and Maximum Power Circuit Distances

110V AWG	14	12	10	8	6	4
MAX RUN (ft)	180	280	460	700	1150	1800

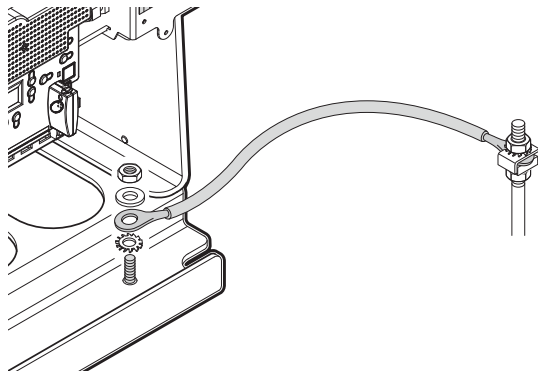

Figure 19 - GROUNDING WIRE

The gate operator should be grounded to a copper rod driven to a minimum depth of 3 feet, and properly grounded to the opener using a 1/4" copper wire prior to operation. Ensure proper ground bonding by removing paint around the mounting hole to create a proper connection if required. (Burnishing may be required) Check conductivity using a multimeter to verify bonding. (Ring-Out). Use a star washer between the ring terminal and the nut to ensure a good ground connection. See figure 19.



WARNING

This slide gate operator uses an inherent entrapment sensing system as well as external type sensors.

WARNING: External entrapment protection must be added to insure a safe vehicular gate operating system.

Entrapment protection must be provided by a combination of non-contact inherent devices. Disconnect power to the gate operator before installing the non-contact sensors.

Actual placement of sensors is dependent on the specific installation requirements.

One or more non-contact sensors should be located where the risk of entrapment or obstruction exists such as the perimeter reachable by a moving gate or barrier.

ISOLATE ALL ELECTRICITY PRIOR TO INSTALLATION OR SERVICE



10 - OPTIONAL INPUTS

10.1 - Fire input

32 FIRE

33 GND

Dry contact input for a fire department control switch. Normally Open (NO) contact must be shorted to ground through a switch to open the gate. Opens the gate and holds the gate open until the control switch is deactivated. This input is "hold to run". Auto-close is disabled when this input is activated. Also clears hard shutdown.

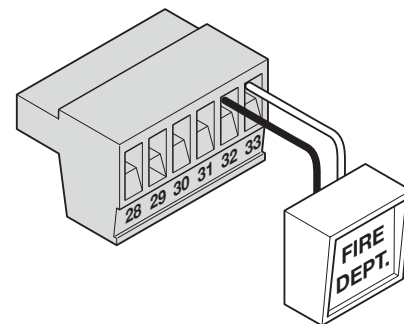

Figure 20 - FAIL SAFE CONNECTOR

10.2 - Fail safe connection

A "fail safe" electric motor brake is provided for each of the three motor control outputs on the main gate control board. A jumper is installed at the factory for the primary motor control as shown in figure 21 to activate this electric brake. This jumper creates an effective brake action on the motor that does not allow the gate to be operated (opened or closed) manually, whether or not the gate operator is powered. This jumper may be removed during a power outage to enable operation of the gate manually, or during installation, the jumper may be removed and this connector may be wired to an external switch for more convenient access. The fail safe jumpers for the Motor 1 and Motor 2 control provide the same electric brake function for external gate motors in alternative installations.

Fail Safe connector with jumper installed on the Primary motor control connectors

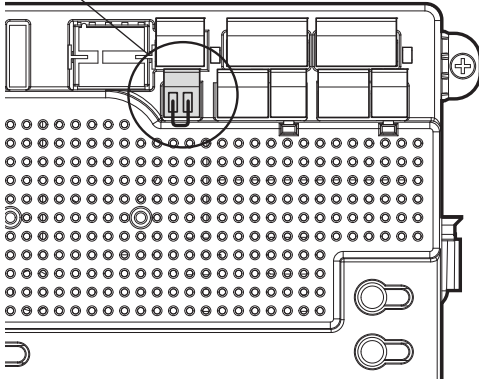

Figure 21 - FAIL SAFE CONNECTION

10.3 - Magnetic lock connection

- 7 NC
- 8 Com (Common)
- 9 NO
- 10 GND
- 11 V+

This connection is used to install the magnetic lock. In this instance a gate can be locked magnetically to prevent a forced opening. Connections to this may be different than shown. Consult lock manual for specifics on installation and wiring.

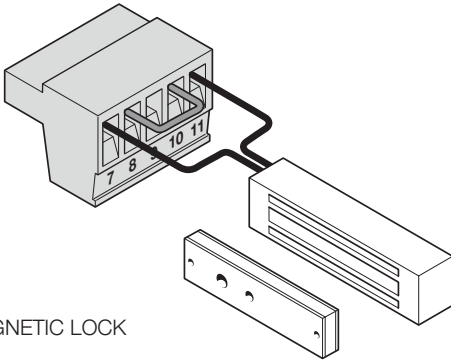

Figure 22 - MAGNETIC LOCK CONNECTION

10.4 - Guard station connection

- 34 OPEN
- 35 STOP
- 36 CLOSE
- 37 GND

With a Guard Station switch in place, a user could operate the gate by pushing the respective buttons for the command that is desired. Gate Open, Stop, and Close dry contact inputs, controlled by NORMALLY OPEN (NO) and NORMALLY CLOSED (NC) momentary switches.

NOTE: If guard station inputs are not used, STOP (35) and GND (32) need to be tied together.

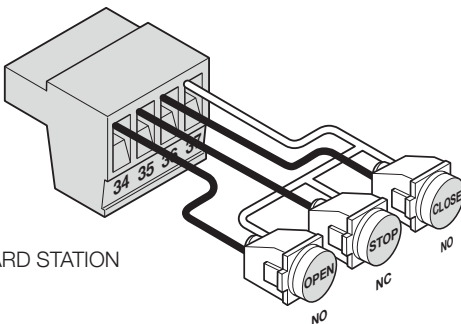

Figure 23 - GUARD STATION CONNECTION

10.5 - Exit and edge inputs wiring diagram

- 28 EDGE
- 29 GND
- 30 EXIT
- 31 GND

The EDGE input may be configured as a monitored ANALOG input, or DIGITAL (NC or NO) input. The EDGE sensor input is intended for ANSI/UL 325 listed gate edge sensors to protect against entrapment and hazardous pinch points along the moving edge of the closing gate. The EXIT sensor input is provided to activate to open the gate, or re-open a closing gate, upon sensing an exiting vehicle.

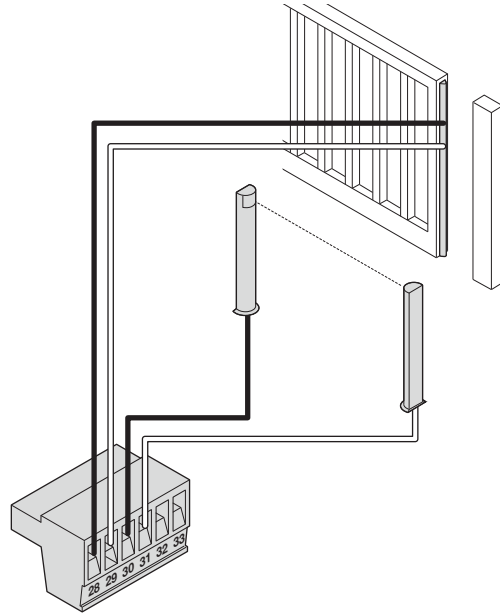

Figure 24 - EXIT AND EDGE INPUTS

10.6 - Radio receiver connection (third party)

- 38 12V
- 39 OPEN
- 40 CLOSE
- 41 GND

The customer supplied radio receiver allows the gate operator to be operated via remote, such as wireless key-card readers or user remote controls. Connecting the Open (39) and Close (40) pins together with a receiver enables single-button gate control. This configuration allows a single button to control the gate in the following sequence:

- Press - Gate Open
- Press - Gate Stop
- Press - Gate Close
- Press - Gate Stop

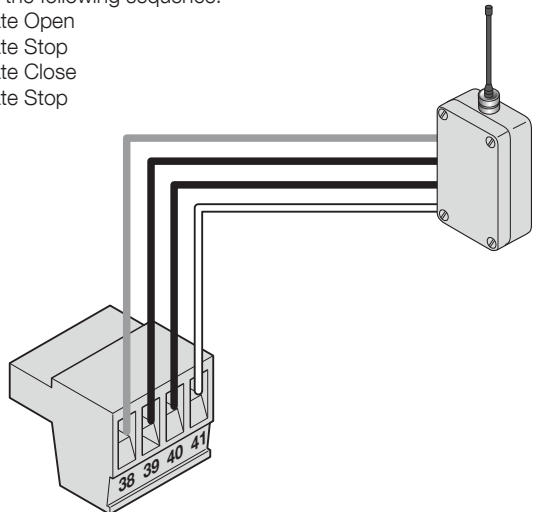

Figure 25 - RADIO RECEIVER CONNECTION

11 - INSPECTION AND OPERATION

Proper inspection of all equipment is required to ensure continuous functionality, safety and to ensure reliable operation in all weather conditions. Inspect electrical assemblies and wiring installations for damage, general condition, and proper functioning to ensure the continued satisfactory operation of the electrical system. Adjust, repair, overhaul, and test electrical equipment and systems in accordance with the recommendations and procedures in the OPENER and/or component manufacturer's maintenance instructions. Replace components of the electrical system that are damaged or defective with identical parts, with manufacturer's approved equipment, or its equivalent to the original in operating characteristics, mechanical strength, and environmental specifications. A partial list of suggested problems to look for and checks to be performed are listed below:

- 11.1** Damaged, discolored, or overheated equipment, connections, wiring, bearing caps and installations.
- 11.2** Excessive heat or discoloration at high current carrying connections. (look for bluing or heat affected metal).
- 11.3** Misalignment of electrically driven equipment. (Causes strain on pulley assemblies and bearings).
- 11.4** Poor electrical bonding (broken, disconnected or corroded bonding strap) and grounding, including evidence of corrosion.

- 11.5** Dirty equipment and connections. Clean equipment and connections.
- 11.6** Improper, broken, inadequately supported equipment, wiring and conduit, loose connections of terminals, and loose ferrules.
- 11.7** Poor mechanical or weld joints. Broken welds.
- 11.8** Condition of circuit breaker and fuses. Ensure that they are of the correct type and amperage.
- 11.9** Insufficient clearance between exposed current carrying parts and ground or poor insulation of exposed terminals. All exposed connections must be covered (prevent arcing between exposed parts, and electrical shock).
- 11.10** Broken or missing wire, connectors, etc.
- 11.11** Operational check of electrically operated equipment such as motors, inverters, generators, batteries, lights, protective devices, etc. Ensure proper functionality of all systems during inspections.
- 11.12** Ensure safety placards and warning signs are present as specified within this document. Ensure proper functionality of all safety devices as specified. Non-functioning or malfunctioning safety devices should be replaced immediately.

12 - GENERAL LAYOUT AND SAFETY ACCESS

Entrapment Protection Inputs - Typical Installation Diagram Utilizing Loop Sensors and Photocells

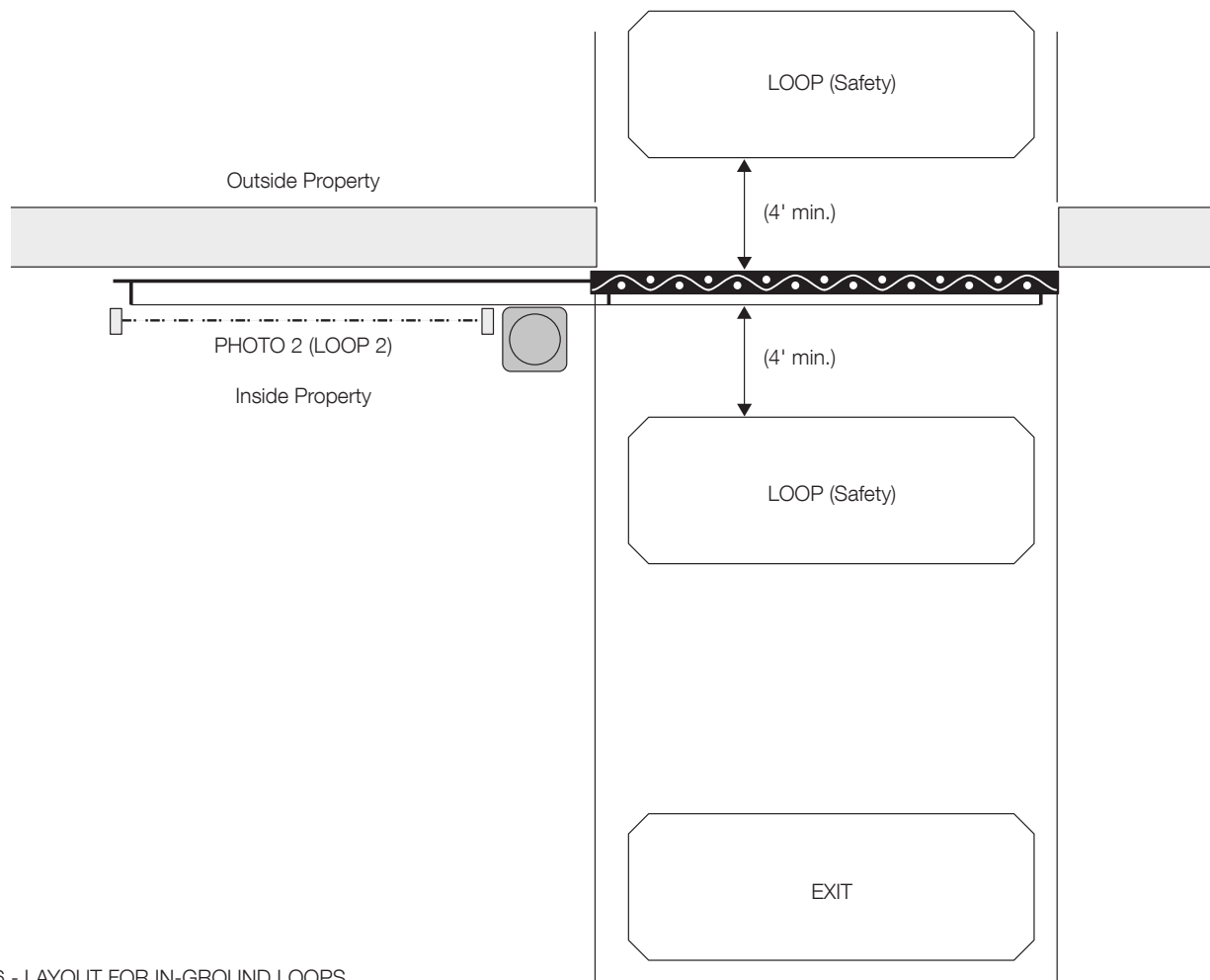

Figure 26 - LAYOUT FOR IN-GROUND LOOPS

Entrapment Protection Inputs - Typical Installation Diagram Utilizing Photocells

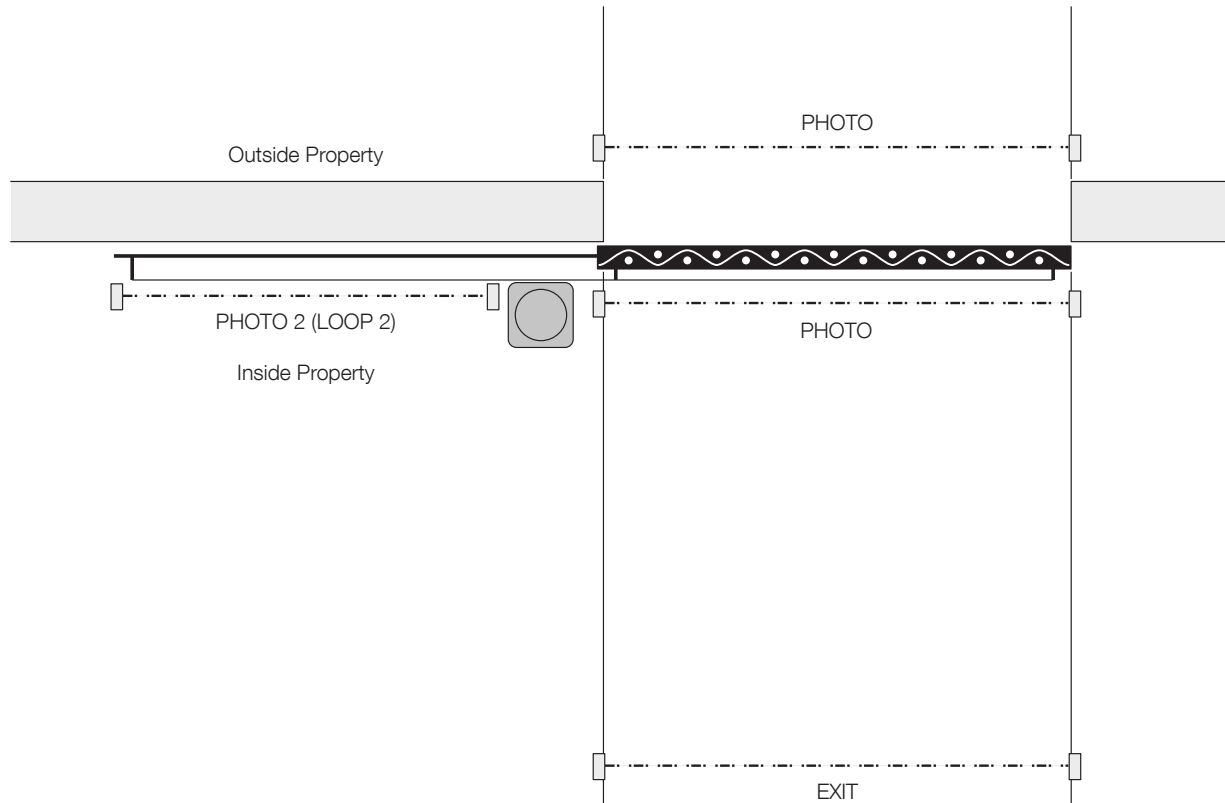

Figure 27 - LAYOUT FOR PHOTO EYES

13 - ACCESSORIES AND SENSORS

EXTERNAL ENTRAPMENT PROTECTION

Non-contact and contact sensors must be installed individually or in combination with each other to provide external entrapment protection.

Care should be exercised to reduce the risk of nuisance tripping, such as when a vehicle trips the sensor while the gate is still moving, and one or more non-contact sensors shall be located where the risk of entrapment or obstruction exists, such as the perimeter reachable by a moving gate or barrier.

A hardwired contact sensor shall be located and its wiring arranged so that the communication between the sensor and the gate operator is not subjected to mechanical damage.

A wireless contact sensor such as one that transmits radio frequency (RF) signals to the gate operator for entrapment protection functions shall be located where the transmission of the signals are not obstructed or impeded by building structures, natural landscaping or similar obstruction.

DURING INSTALLATION

- DISCONNECT POWER at the control panel before making any electric service power connection.
- Be aware of all moving parts and avoid close proximity to any pinch points.
- Know how to operate the manual release.
- Adjust the unit to use the minimum force required to operate the gate smoothly even during mid-travel reversing.

- Place controls a minimum of 8 feet away from the gate so that the user can see the gate and operate controls but cannot touch the gate or gate operator while operating the controls.
- Warning signs must be placed on each side of the gate or in high-visibility areas to alert of automatic gate operations.



14 - BOARD NOMENCLATURE

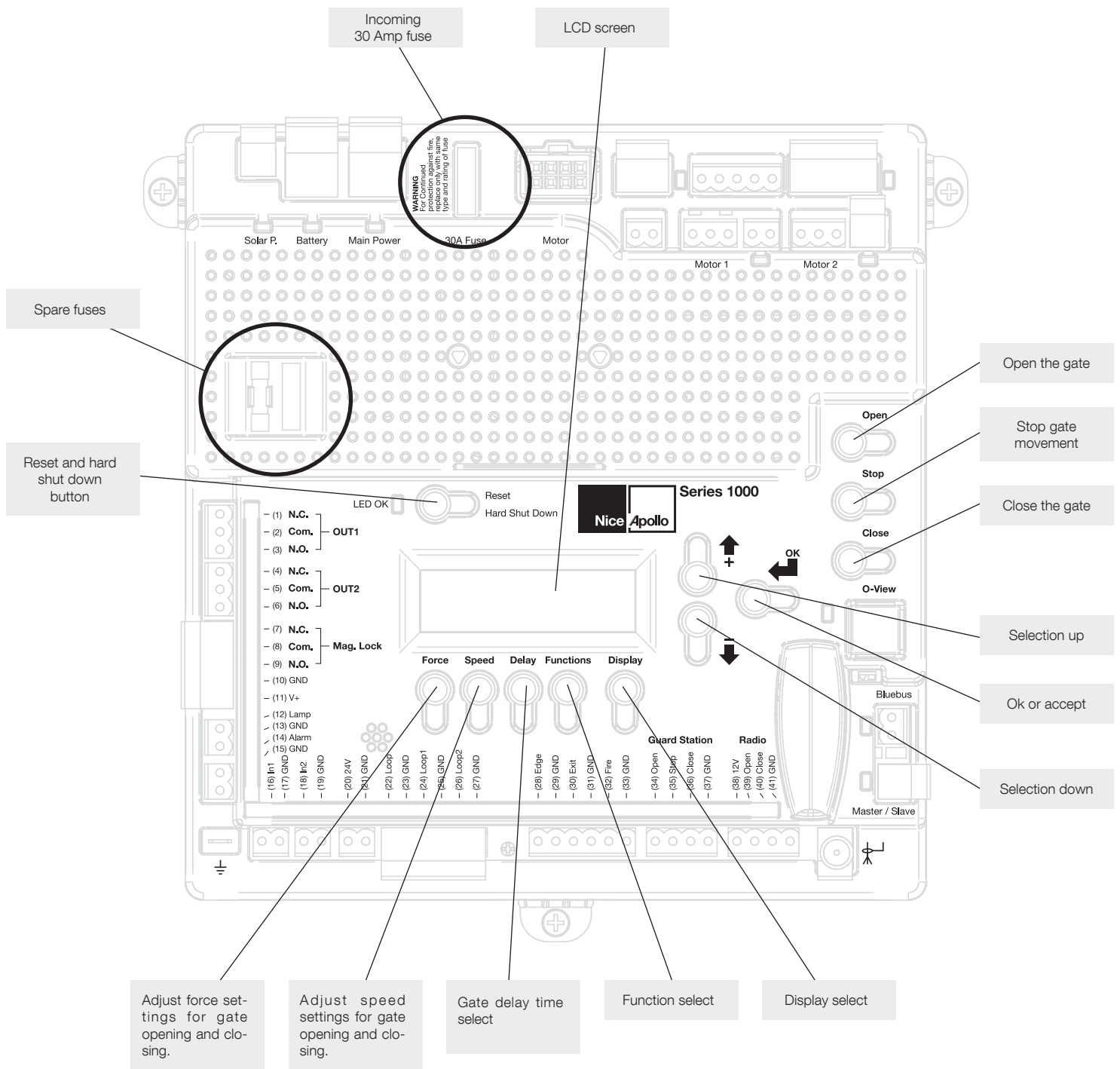

Figure 28 - GENERAL BOARD OVERVIEW

THE PROGRAMMING BUTTONS INDICATED IN THE ABOVE REFERENCE SHOULD BE USED ONLY AFTER UNDERSTANDING THE MANUAL AND ITS RELATION TO THE PROGRAMMING SEQUENCES SHOWN ON THE FOLLOWING PAGES. CARE SHOULD BE TAKEN WHENEVER CHANGES ARE IMPLEMENTED TO ENSURE PROPER FUNCTIONALITY AND SAFETY.

15 - PROGRAMMING BUTTONS

15.1 - Force

Static: Set sensitivity to constant force on a scale of 1 to 10 (1 being the most sensitive).

Dynamic: Set sensitivity of sudden impact force to the moving gate on a scale of 1 to 10 (1 being most sensitive).

ESC: Exit the FORCE menu.

15.2 - Speed

Max: Sets the limit of maximum allowed gate speed on a scale of 20% to 100% (20% being the lowest setting).

Standard: Sets the limit of the gate speed during normal movement (not soft start/stop) on a scale of 20% to MAX (20% being the lowest setting).

Low: Sets the limit of the gate speed while in LEARNING mode and when moving in SLOW, on a scale of 20% to STANDARD (20% being the lowest setting).

Slowdown: Set gate speed when going into approaching the open or close limits on a scale of 20% to LOW (20% being the lowest setting).

15.3 - Acceleration

Max: Sets the limit of gate acceleration when reversing the gate after an obstacle has been detected by the UL/Edge or current sense feature (Force). Settings from 1 to 10, with 10 being the highest rate of gate acceleration. *

Standard: Sets the limit of the gate acceleration in normal operation. Settings from 1 to 10, with 10 being the highest rate of gate acceleration. *
*TO PREVENT DAMAGE TO THE GATE OR THE CONTROLLER USE LOWER ACCELERATION SETTINGS FOR HEAVIER GATES.

ESC: Exit the SPEED menu.

15.4 - Delay

Auto Close: Sets the timeout before the gate closes automatically from the fully open position. Settings from 5 to 120 seconds.

Slave: Sets the delay for opening the slave gate leaf in a Master/Slave (Motor 1 and Motor 2 operation), (dual gate) system. Settings from 0 to 5 seconds with a step of 0.5 seconds.

Lamp/Strobe: Sets the amount of time the Lamp accessory output is activated prior to gate movement. Settings from 0 to 5 seconds with a step of 0.5 seconds.

Lock: Sets the amount of time the Magnetic Lock accessory output is activated to disable the lock when opening the gate. Settings from 0 to 5 seconds with a step of 0.5 seconds.

Run Time: Sets the maximum run time for the gate. Used in case the gate doesn't reach its limits. Settings from 5 to 120 seconds with a step of 1 second.

ESC: Exit the DELAY menu.

15.5 - Function

Learn: Puts the gate operator into learning mode for a slide or slide gate, and Blue BUS peripherals. Learning mode for a slide style gates involves selecting the gate type (Light, Average, Heavy), then fully opening and closing the gate to sense the limits. Selecting the gate type selects pre-calculated values for the FORCE, SPEED, and ACCELERATION settings. Learning the Blue BUS peripherals enables the gate operator to discover and integrate accessory devices like Blue BUS access control and safety devices.

Positions: Configures the points in the gate open, close, and partial cycles at which deceleration occurs.

- Slow Down – Open: Sets the point in the % of gate opening when the gate begins deceleration to the fully open position.

- Slow Down – Close: Sets the % of gate opening when the gate begins deceleration to the fully close position.
- Partial: Sets the point in the % of gate opening when the gate begins deceleration to the Partial open position.

Auxiliary Inputs: Auxiliary inputs IN AUX1 (16) and IN AUX2 (18) can be programmed with one of the following options:

- No program No Function used
- OPEN the Gate
- CLOSE the Gate
- STEP Cycling Step (Open-Stop-Close-Stop)
- PARTIAL opening
- PARTIAL 1 Partial Opening 1 (open one leaf in dual gate applications)
- STOP the gate and Auto-closing
- HOLD TO OPEN Input must be maintain active for Opening
- HOLD TO CLOSE Input must be maintain active for Closing
- FIRE Reset Hard Shut Down and Open the Gate
- TIMER 1 Start Count Down TIMER1
- TIMER 2 Start Count Down TIMER2
- PHOTO Photocell PHOTO input: reverse to opening when closing
- PHOTO1 Photocell PHOTO1 input: Stop Gate when activated
- PHOTO2 Photocell PHOTO2 input: reverse to closing when opening
- SHADOW Loop input: prevent closing gate when completely open
- BLOCK system from other command (only STEP H overrides the Block)
- UNBLOCK Un-block the system if blocked
- OPEN and BLOCK Open the Gate and inhibit further commands (except STEP H)
- CLOSE and BLOCK Close the Gate and inhibit further commands (except STEP H)
- OPEN and UNBLOCK Open the Gate and un-inhibit further commands
- CLOSE and UNBLOCK Close the Gate and un-inhibit further commands
- STEP H Command high priority Step cycling (open-stop-close-stop)

Auxiliary Outputs: Auxiliary outputs OUT AUX1 (1,2,3,) and OUT AUX2 (4,5,6,) can be programmed with one of the following options:

- NO PROGRAM Output not used
- OPEN Output is activated when Gate is open
- CLOSE Output is activated when Gate is closed
- MOVING Output is activated when Gate is moving
- TIMER 1 Output is activated when TIMER1 is counting down
- TIMER 2 Output is activated when TIMER2 is counting down

Radio Channel: For the Plug-in Onboard Receiver, 15 radio channels may be programmed with one of the following options:

- No program
- OPEN (Default CH. 2)
- CLOSE
- STEP (Default CH. 1)
- PARTIAL
- PARTIAL
- STOP
- HOLD TO OPEN
- HOLD TO CLOSE
- FIRE
- TIMER 1
- TIMER 2
- PHOTO
- PHOTO1
- PHOTO2
- SHADOW
- BLOCK
- UNBLOCK
- OPEN and BLOCK
- CLOSE and BLOCK
- OPEN and UNBLOCK
- CLOSE and UNBLOCK
- STEP H

Timers: Set time for count down timers Timer 1 and Timer 2. Settings between 1 second and 9 hours in 1 second increments.

Events: Up to 8 weekly events (EV1 through EV8) can be programmed and stored. Each event can be programmed to trigger at a specific time and can

be assigned to any combination of days of the week (Monday through Sunday). Events that are already programmed into the system may be suspended temporarily, or removed permanently from memory. The following actions can be assigned to events:

- No program
- Open
- Close
- Partial
- Partial1
- AxOut1On
- AxOut1 Off
- AxOut2 On
- AxOut2 Off
- Block
- Unblock
- Open and Block
- Close and Block
- Open and Unblock
- Close and Unblock

To program weekly events EV1 through EV8, perform the following steps:

1. Press FUNCTION -> Events.
2. Press and hold OK to display EV1 (display will blink "EV1").
3. Press UP or DOWN to toggle between events, then press OK to make a selection. The display changes to hours.
4. Press UP or DOWN to toggle between hours, then press OK to make a selection. The display changes to minutes.
5. Press UP or DOWN to toggle between minutes, then press OK to make a selection. The display changes to individual days of the week.
6. Press UP or DOWN to toggle between days of the week. Press OK to toggle between ON and OFF for each day of the week. Continue toggling through the days of the week until ESC is displayed. Press OK to advance to the next event.
7. Repeat step 2 through 6 for event EV2 through EV8.

To temporarily suspend one or more weekly events (EV1 through EV8), perform the following steps:

1. Press FUNCTION -> Events.
2. Press OK quickly to display EV1 active days.
3. Press OK quickly again to display "Suspend". Event EV1 is now suspended and will not run until re-enabled.
4. Press UP or DOWN to toggle through the events EV1 – EV8 and repeat steps 2 through 3 to suspend or enable other weekly events.

Charger: A battery charger is built-in with the Control board for use with a backup battery. The charger may be manually programmed for customized charge settings or set to "Auto" to provide a battery charging profile that automatically compensates for temperature and current during the charging process. The following parameters are available for programming the battery charger:

- Charger On/Off
- Select Max current for charging (from 0.1A to 1.5A step 0.05A)
- Cycling Time (1 second off charging every cycling time)
- Auto (best charge considering temperature)

Standby: Programs the timeout for the gate operator to go into low power standby mode. Low power standby is Settings from 5 to 120 seconds, or may be disabled with "OFF". During low power standby there is no data displayed on the gate operator LCD and it consumes a minimum amount of power to extend the life of the backup battery. All the outputs are switched off and the LED OK blinks to show this standby status of the system.

Advance Settings: The following settings are available for customizing the gate operator as required by the customer's installation requirements:

- Set Language (English Spanish Italian)
- Set clock 12H/24H
- Set LCD Contrast
- Set Direction Opening (Adapts the motor direction as necessary depending upon the opening direction of the slide or gate)
- Set Virtual Encoder (Used for motors without built-in encoders)
- Set Anti-tailgate (Closes gate immediately after vehicle has cleared safety sensors)

- Select inputs LOOP or PHOTO
- Select UL/EDGE input type (NO, NC, Analog)
- Select Master / Slave Motor1 or Motor2
- Activate link for remote Master/Slave (Enables control of an additional gate operator board)
- Power Fail Open (Opens gate automatically on batter backup power if main AC power input loss is detected)
- Motor 12V (Forces motor control voltage to +12VDC even if the supply voltage varies from +9.5VDC up to +35VDC)

Default: This setting gives the installer/user the option of returning some or all settings of the gate operator to the original factory settings:

- System settings
- Radio Channel settings
- Event settings
- Charger settings

ESC: Exit the FUNCTION menu.

15.6 - Display

ESC: Exit the DISPLAY menu.

Info: Displays the manufacturer name, product name/model, software versions, and serial number.

Clock: Displays the calendar date and time in the real time clock. Pressing and holding the "OK" button for 5 seconds enables the date and time settings to be updated manually.

Main Volt: Displays the gate operator main control voltage in volts DC.

Battery Volt: Displays the gate operator backup battery voltage in volts DC.

Sun Volt: Displays the solar panel input voltage in volts DC.

Motor Volt: Displays the voltage at the motor in volts DC.

UL Volt: Displays the voltage at the UL/Edge sensor input in volts DC.

Temperature: Displays the temperature of the gate controller board in degrees Centigrade or Fahrenheit (press OK and hold 5 seconds to change scale).

Service: The following information is recorded and viewable about the operating history of the gate:

- Total: Displays the total number of open-close cycles (non- Settings).
- Partial: Display the total number of partial cycles. Reset by pressing the "OK" button for several seconds.
- Maint. Display the number of cycles before service is required. Settings from 1000 to 50000 cycles in increments of 1000 cycles.

Motor: Displays the Motor position, voltage, and current.

Motor 1: Displays the Motor1 position, voltage, and current.

Motor 2: Displays the Motor2 position, voltage, and current.

Charger: Displays the battery charger voltage and current.

Last Reset: Displays the code for diagnostic review. Used for diagnostic and troubleshooting.

ESC: Exit the DISPLAY menu.

16 - GATE DIRECTION REVERSAL

WARNING: GATE DIRECTION REVERSAL CAN ONLY BE ACCOMPLISHED IN LEARNING MODE

Gate Direction Reversal

If for some reason, the installer were to install the opener on the opposite side of the gate from which the unit is programmed, and when you press the OPEN button, the gate actually CLOSES, the installer will need to REVERSE the direction of travel to match the buttons on the control board.

Press OPEN and note if the gate actually opens. If it does not, and instead is traveling in a CLOSING direction follow the below steps to correct; (if already in learning mode, follow the below listed steps)

1. Press FUNCTION
2. Scroll through the options to reach "ADVANCED SETTINGS"

3. Press ENTER
4. Scroll through selection to reach "DIRECTION OF MOTOR"
5. Press ENTER
6. The direction arrows on the display begin to blink.
7. Choose the appropriate direction of travel
8. Press DISPLAY to return to the MAIN MENU
9. Press OPEN to verify that the gate now OPENS.

If not in learning mode, follow the listed steps in the next column.

Steps on how to place the Apollo 1050 control board into learning mode.

1. Press Function
2. Press OK
3. Select SLIDE
4. Select LIGHT, AVERAGE OR HEAVY
5. Press Enter

17 - RE-ASSEMBLING GATE OPERATOR

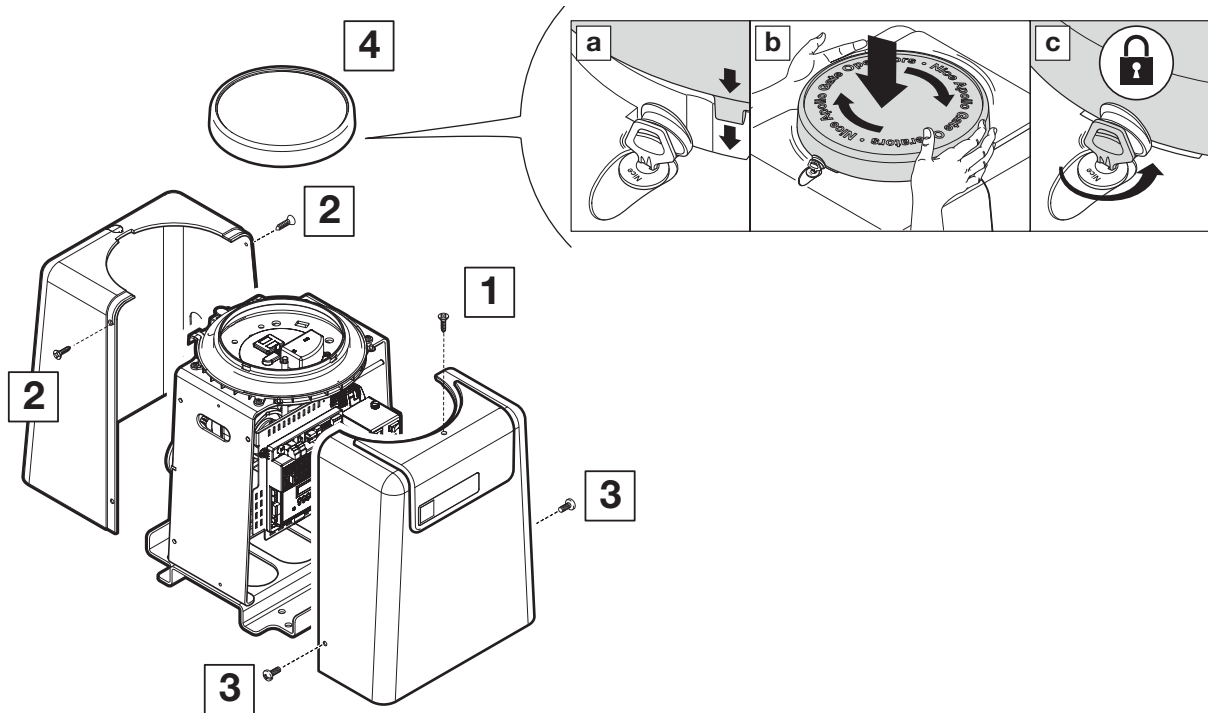

18 - EMERGENCY VEHICLE ACCESS

- 18.1 The automatic vehicular gate system must be designed to allow access to emergency vehicles under different operating conditions.
- 18.2 During normal powered operation, emergency vehicles access the gate by use of the emergency vehicle access device installed on your gate system. The type of device that is used in your community is dependent on your city codes. These devices may include (but are not limited to) Fire Department lock boxes, Click-2-Enter radio receivers, strobe light sensors, siren sensors, etc.
- 18.3 Check with your installer to determine if your gate system is equipped with a back-up power system. In the event of a primary (AC) power failure and a back-up system (DC) power failure (low charged or dead batteries for example), the system must have a release system to allow the gate to be manually operated.
- 18.4 This operator is equipped with a manual release system that will allow the gate to be pushed open in the event of a power outage or equipment failure.

- 18.5 **NOTE:** Never attempt to manually push open any gate with an operator attached to it until you have verified that power to the operator has been shut-off.
- 18.6 The automatic vehicular gate system must be designed to allow access to emergency vehicles under different operating conditions.
- 18.7 In the event of a power failure, the emergency vehicle access device may not be functional because the gate operator is un-powered. **NOTE:** DC powered back-up systems are optional and your gate system may or may not be equipped with one. Check with your installer to determine if your gate system is equipped with a back-up power system.
- 18.8 The FAIL-SAFE manual operation system is the most reliable and safest method for placing an automated gate in manual operation and is the preferred method of emergency gate operation under worse case conditions by many Fire Chiefs and Building Inspectors and is typically used in CLASS I and CLASS II applications.
- 18.9 For manual fail-safe gate operation, turn power to the operator OFF. If a backup power system is in use, be sure that this power is turned OFF also. Once power is OFF, the gate can be manually operated, by using the MANUAL RELEASE handle under the top cover.

19 - GLOSSARY

BLOCK - Ceases all operator function except HIGH PRIORITY inputs.

COMMERCIAL / GENERAL ACCESS VEHICULAR GATE OPERATOR-CLASS II - A vehicular gate operator (or system) intended for use in a commercial location or building such as a multi-family housing unit (five or more single family units), hotels, garages, retail store, or other building servicing the general public.

ENTRAPMENT - The condition when an object is caught or held in a position that increases the risk of injury.

FORCE STATIC - Constant load threshold for sensitivity setting.

FORCE DYNAMIC - Impact sensitivity setting.

GATE - A moving barrier such as a swinging, sliding, raising, lowering, or the like, barrier, that is a stand-alone passage barrier or is that portion of a wall or fence system that controls entrance and/or egress by persons or vehicles and completes the perimeter of a defined area.

(STEP H) HIGH PRIORITY - Step by step control

INHERENT ENTRAPMENT SENSOR SYSTEM - An automatic sensor system which senses entrapment of a solid object and is incorporated as a permanent and integral part of the operator.

INDUSTRIAL / LIMITED ACCESS VEHICULAR GATE OPERATOR-CLASS III - A vehicular gate operator (or system) intended for use in an industrial location or building such as a factory or loading dock area or other locations not intended to service the general public

RESTRICTED ACCESS VEHICULAR GATE OPERATOR-CLASS IV - A vehicular gate operator (or system) intended for use in a guarded industrial location or building such as an airport security area or other restricted access locations not servicing the general public, in which unauthorized access is prevented via supervision by security personnel.

RESIDENTIAL VEHICULAR GATE OPERATOR-CLASS I - A vehicular gate operator (or system) intended for use in a home of one-to four single family dwelling, or garage or parking area associated therewith.

STEP BY STEP - Command that opens-stops-closes-stops the gate with each press of the button.

SYSTEM - In the context of these requirements, a system refers to a group of interacting devices intended to perform a common function.

UNBLOCK - Resumes normal operation after a blocked condition.

WIRED CONTROL - A control implemented in a form of fixed physical interconnections between the control, the associated devices, and an operator to perform predetermined functions in response to input signals.

WIRELESS CONTROL - A control implemented in means other than fixed physical interconnections (such as radio waves or infrared beams) between the control, the associated devices, and an operator to perform predetermined functions in response to input signals.

20 - MAINTENANCE SCHEDULE - APOLLO GATE OPENER

Table 2

		COMPLETE	BASIC
Alarm	Active the primary (inherent)reverse system by blocking the gate with a solid object. The gate should reverse momentarily then stop. Restart the gate and block again with a solid object. The gate should reverse momentarily, then stop, and go into hard shutdown with an alarm	●	●
Backup System	If operator is equipped with option DC backup system, check to be sure the system opens the gate upon loss of AC power	●	●
Battery	If operator is equipped with option DC backup system, check the batteries for any leakage or loose connections. Batteries should be replaced every two years	●	
Drive Chain	Check for alignment, tightness and wear	●	
Fire Dept	Check emergency vehicle access device for proper operation	●	●
Gate	Inspect for damage. Check gate rollers for wear and grease if necessary	●	
Chain lube	Main Sprocket and chain	●	
Reverse System	Check that the gate reverses on contact with an object in both the opening and closing cycles	●	●
Loop(s)	Check vehicular reverse and shadow loops for proper operation	●	●
Release	Check manual release for proper operation	●	
Complete	Overall Check: Complete check of gate and gate operating system	●	
Mounting Hardware	Check screws and nuts	●	
Rain Drain	Remove top lid and sweep out any debris or dust that may have accumulated. Every 6 months.	●	

CORRECT LAYOUT

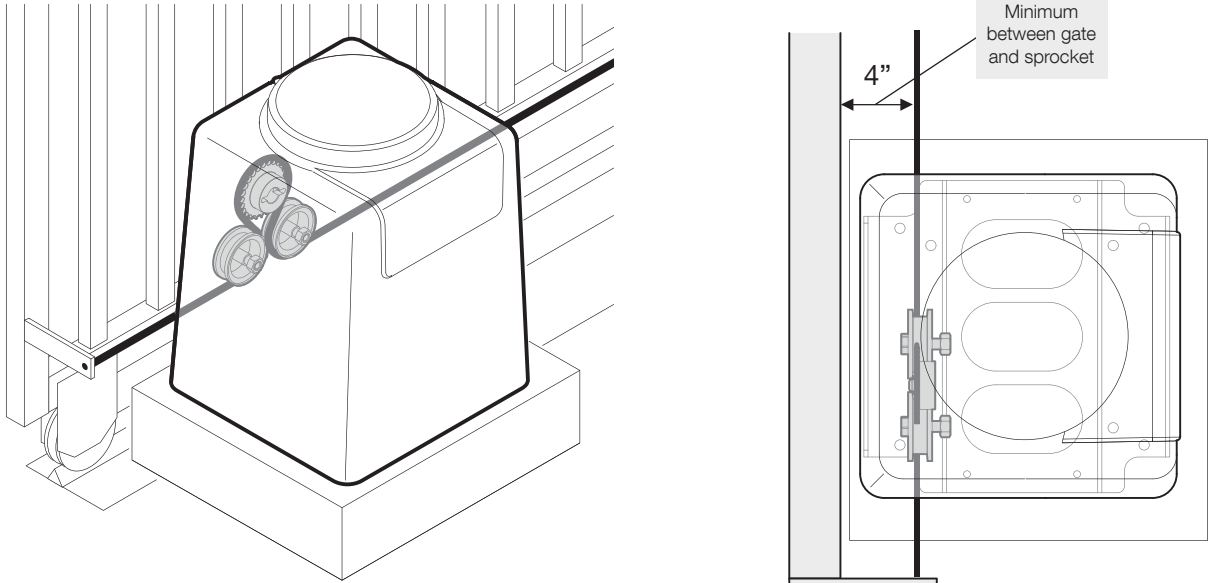

Figure 29

INCORRECT INSTALLATION

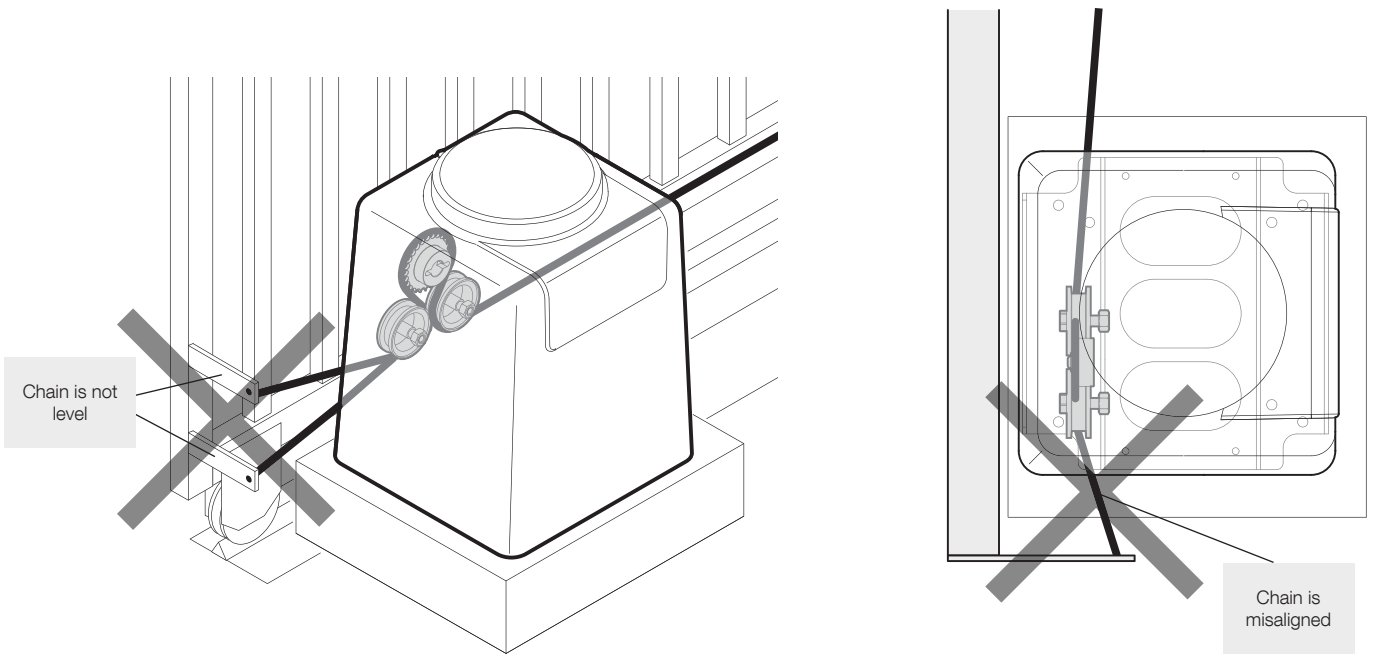

Figure 30

22 - APOLLO GATE OPENER TROUBLESHOOTING

Table 3

SYMPTOM(S)	POSSIBLE SOLUTION
Operator will not Power On. Power LED is OFF	Check that power to the operator is turned ON Check terminal block wiring for loose or broken wires Check for 115 VAC at source. If voltage measures OK, check the terminal block Check the fuse
Gate opens a short distance, then stops and reverses	Check the UL/Edge input on the gate controller Adjust Force Settings
Gate opens but will not close	Check the input LEDs. Any ON will hold the gate open and indicates a problem with a keying device Check the secondary safety devices. Any activated safety device will hold the gate open and indicates a problem with the safety device Check the loop detectors. Any activated safety device can hold the gate open and indicates a problem with the loop detector or ground loop
Battery backup system will not open gate upon AC power outage	Check if backup system is set to open gate automatically or requires an input to open Check the batteries for proper voltage. Replace if necessary
Hard Shutdown (2 back to back obstructions) LED blinking, Buzzer sounds for 5 minutes	Clear any obstructions from the path of the gate. Press RESET to clear (or hard reset button)
Gate opens by itself	Check accessory inputs and clear them as necessary

23 - PROGRAMMING QUICKSTART

23.1 - Learning the gate

1. Install electrical power to the gate opener unit.
2. Install all gate accessories such as Photo-Eye's, Sensors, Loops and other safety devices.
3. Turn on the electrical power to the unit.
4. Using the MANUAL RELEASE HANDLE, disengage the drive motor.
5. Move the gate manually (with your hands) to ensure that the gate travels to the fully open and fully closed positions with no binding or problems. Gate should move freely.
6. Using the MANUAL RELEASE HANDLE, re-engage the drive system and stow the handle.
7. Using the open button on the front of the Control board, hold the button down until the gate reaches the fully open position.
8. Adjust the Open Limit Switch until the GREEN light illuminates on the front of the control board. The FULLY OPEN limit switch is now set.
9. Using the CLOSE button on the front of the Control Board, hold the button down until the gate reaches the fully closed position.
10. Adjust the CLOSED Limit Switch until the RED light illuminates on the front of the control board. The fully CLOSED limit switch is now set.
11. The control board is already in the "LEARNING MODE" when shipped. (If not in LEARNING MODE see section 26.3) Press "OK" to allow the control board to scan for attached items, such as sensors, photo-eye's and other safety devices.
12. The gate will open partially, then stop. This is being done, so that the control board can sense the type and operational condition of the drive motor. The gate will then run to the closing limit, so that it can properly sense where it is located.
13. The control board will then OPEN the gate slowly to establish travel and limits.
14. Once the gate reaches the fully OPENED limit switch, the control board will now increase gate travel speed to the highest speed allotted, and will now travel to the fully CLOSED position at full speed.

15. The gate opener is now programmed for basic usage.

23.2 - Gate direction reversal

WARNING: GATE DIRECTION REVERSAL CAN ONLY BE ACCOMPLISHED IN LEARNING MODE

If for some reason, the installer were to install the opener on the opposite side of the gate from which the unit is programmed, and when you press the "OPEN" button, the gate actually CLOSES, the installer will need to REVERSE the direction of travel to match the buttons on the control board.

Press "OPEN" and note if the gate actually opens. If it does not, and instead is traveling in a CLOSING direction follow the below steps to correct:

1. Press FUNCTION
2. Scroll through the options to reach "ADVANCED SETTINGS"
3. Press ENTER
4. Scroll through selection to reach "DIRECTION OF MOTOR"
5. Press ENTER
6. The direction arrows on the display begin to blink
7. Choose the appropriate direction of travel
8. Press DISPLAY to return to the MAIN MENU
9. Press OPEN to verify that the gate now OPENS

If not in learning mode, follow the below listed steps.

23.3 - Putting the controller into learning mode

Steps on how to place the Apollo 1050 control board into learning mode.

1. Press Function
2. Press OK
3. Select Slide
4. Select weight of gate
5. Press Enter

Unit should now be in LEARNING MODE

24 - INSTALLATION CHECKLIST

Left box is for installer check off and the right box is for customer check off.

- 1. The gate has been checked to make sure it is level and moves freely in both directions.
- 2. Potential pinch areas have been guarded so as to be inaccessible OR have contact and/or non-contact obstruction sensing devices installed.
- 3. The installer has installed one or more contact or non-contact obstruction sensing devices, in compliance with UL325 requirements for this installation.
- 4. If pedestrian traffic is expected, a separate pedestrian gate has been installed, a minimum of seven feet from the gate. The customer has been informed that all pedestrian traffic must use the pedestrian gate.
- 5. Warning signs have been installed on each side of the gate in highly visible locations. The customer has been informed that these signs must remain at all times.
- 6. There are no controls installed on the gate operator, or within 8 feet of the gate.
- 7. The installer has properly adjusted the obstruction sensing feature and has tested the gate to make sure that the gate stops and reverses a short distance with minimal resistance applied (Approximately 75 lbs. on a slide gate).
- 8. The installer has instructed the customer in the proper use of the gate operator and reviewed all of the operational functions, obstruction sensing devices, warning beeper and reset, etc.
- 9. The installer has instructed the customer in the proper use of the operator's manual disconnect feature. The manual disconnect must never be used while the gate is in motion. The power switch must be turned off before using the manual disconnect and disengaging the operator.
- 10. The installer has reviewed all safety instructions with the customer, and has left the safety instructions and owner's information sheets for their reference.
- 11. The installer has answered any questions the customer has regarding the operation of the gate operator and gate operator safety precautions.
- 12. The installer has explained to the customer that a regular maintenance schedule for both the gate and the gate operator is recommended.

Installation Acceptance

Address where opener is located

Installer name, number and address

End user name and telephone number

Contact us

Nice Group USA Inc.
12625 Wetmore Road Suite 218
San Antonio, TX 78247
Ph. +1.210.545.2900
Fax +1.210.545.2915
info@us.niceforyou.com

www.apollogate.com
www.niceforyou.com

