

# APOLLO *Gate Operators, Inc.*

## *Model 3500ETL/3600ETL Commercial Swing Gate Operator*

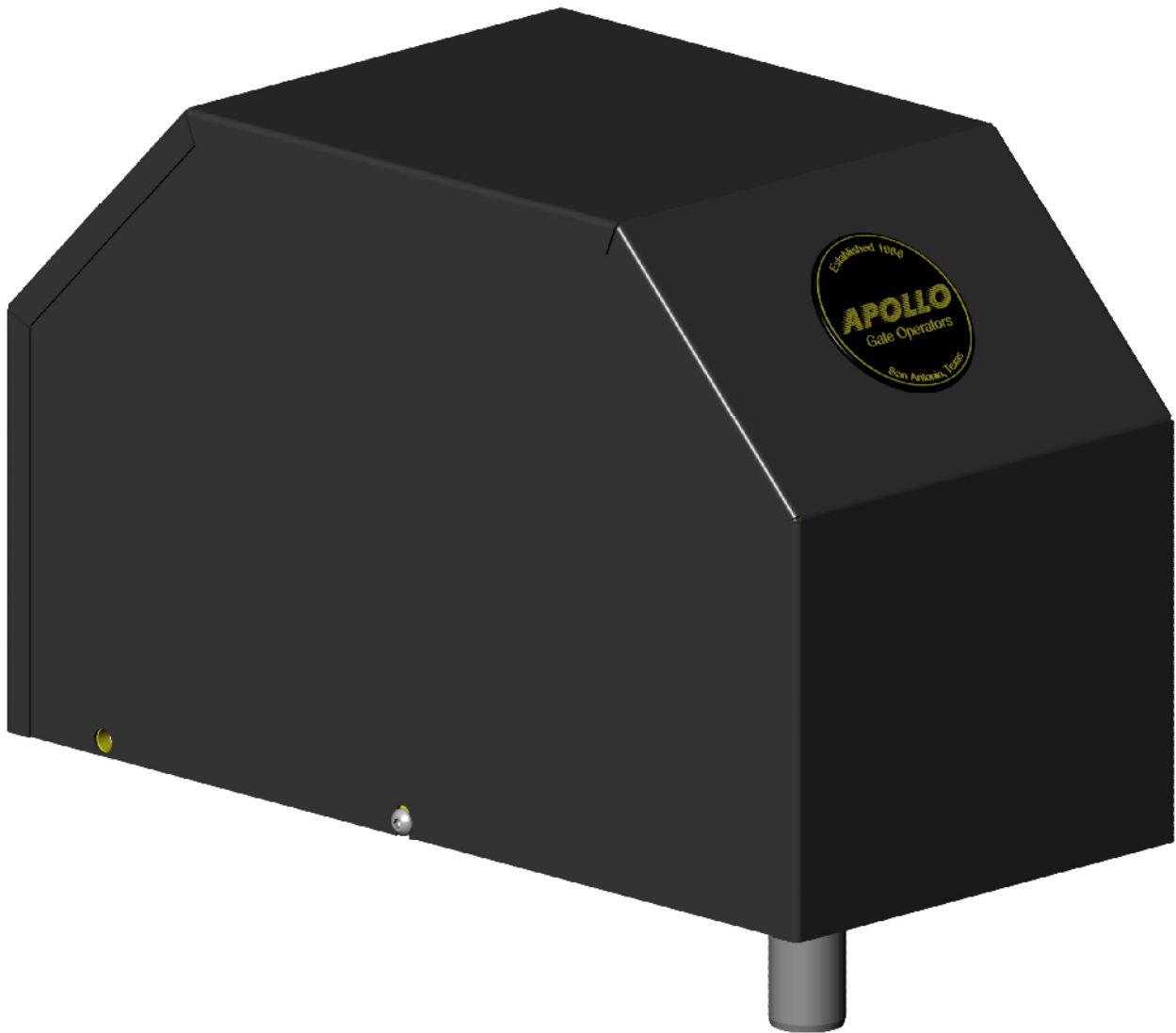

## INSTALLATION MANUAL

# CONTENTS

<b>IMPORTANT SAFETY INSTRUCTIONS.....</b>	<b>3</b>
<b>Applications .....</b>	<b>4</b>
<b>Pre-Installation Checklist .....</b>	<b>5</b>
<b>Parts Identification .....</b>	<b>6</b>
<b>Post Location Guide .....</b>	<b>7</b>
<b>Operator Installation .....</b>	<b>8-13</b>
<b>EMERGENCY MANUAL OPERATION .....</b>	<b>13</b>
<b>Programming Current Sensing .....</b>	<b>14</b>
<b>835/836 Control Board Description .....</b>	<b>15-19</b>
<b>Siren Installation .....</b>	<b>20</b>
<b>Radio Receiver Options .....</b>	<b>21</b>
<b>Troubleshooting guide .....</b>	<b>22-24</b>
<b>Warranty .....</b>	<b>25</b>

# IMPORTANT SAFETY INSTRUCTIONS

**WARNING - To reduce the risk of injury or death:**

- **READ AND FOLLOW ALL INSTRUCTIONS.**
- **Installation should be performed by a professional installer.**
- **Required welding should be performed by a qualified welder.**
- **Should electricity be required, use a certified electrician only.**
- **Any device that requires 120 Volts AC should be U.L. approved.**
- **Review with the owner all safety concerns including:**
  - ⇒ **Do not operate the gate unless area around gate is in full view.**
  - ⇒ **Never let children operate or play with gate controls. Keep the remote control away from children.**
  - ⇒ **Always keep people and objects away from the gate. NO ONE SHOULD CROSS THE PATH OF THE MOVING GATE.**
  - ⇒ **Periodically test the obstruction sensitivity to assure safe and proper operation. *Do not test sensitivity by standing between the gate and the hinge or stop post.***
  - ⇒ **The “CAUTION AUTOMATIC GATE” signs should be clearly visible from both sides of the gate.**
  - ⇒ **Always insure that the gate has closed securely before leaving area.**
  - ⇒ **Arrange with local fire and law enforcement for emergency access.**
- **Use the emergency release only when the gate is not moving.**
- **A secondary entrapment device such as loop detectors, edge switches, and beam detectors are highly recommended and required to meet the UL325 standard.**
- **Install control devices such as keypads far enough away (5 feet or further) from any moving parts of the operator and gate to prevent possible injury.**
- **Do not install control box where the gate can come in contact with person using the push button on side of control box.**
- **Always disconnect the battery or power source when making adjustments or repairs to any part of the gate or operator.**
- **All rollers should be covered to prevent injury.**
- **KEEP GATES PROPERLY MAINTAINED. Read the owner’s manual. Have a qualified service person make repairs to gate hardware.**
- **The entrance is for vehicles only. Pedestrians must use separate entrance.**

**Test the gate operator monthly. The gate MUST reverse on contact with a rigid object or stop when an object activates the non contact sensors. After adjusting the force or limit of travel, retest the gate operator. Failure to adjust and retest the gate operator properly can increase the risk of injury or death.**

**SAVE THESE INSTRUCTIONS.**

# APPLICATIONS

The Model 3500/3600 Swing Gate Operator is designed for residential and commercial applications. The 3500/3600 is listed with ETL and complies with the **UL 325** standard. The 3500/3600 will handle swing gates up to 20 feet in length and 1,000 pounds each. A professional fence or gate dealer is recommended to assure proper installation. The Model 3500/3600 operator is 12 Volt DC (*Direct Current*) powered. There are several advantages with 12 Volt DC systems:

- **Low voltage virtually eliminates risk of electrical shock.**
- **Battery powered operators provide up to 200 operations in the event of power outages.**
- **The battery may be recharged with a battery charger or by solar energy (Electrical battery chargers should have a class 2 transformer rating).**

If a battery charger is used and a standard electrical outlet is not readily available, a licensed electrician will be required for proper electrical hook up.

The following table should be used as a guide for capacity of operation of operators only, additional options may reduce the the daily usage. *Please note that the charge capability of solar panels will vary with different geographical locations.*

Daily Cycles →	1-10	1-20	1-40	1-60	1-80	80+
5 watt solar panel	*					
10 watt solar panel		*				
20 watt solar panel (requires 5310 regulator)			*			
30 watt solar panel (requires 5310 regulator)				*		
40 watt solar panel (requires 5310 regulator)					*	
1.5 amp battery charger					*	
10 amp battery charger						*

*Note: Double the amount of solar panels for Dual Gate Operators.*

# PRE-INSTALLATION CHECKLIST

**Verify that the application will not exceed the operator specifications.**

**Verify proper installation and operation of the gate.**

- 1. Are the hinges servicable?*
- 2. Does the gate swing free and level?*
- 3. Will the gate require a locking device?*
- 4. Is the hinge and stop posts sturdy enough to handle the gate & operator?*
- 5. Does the gate meet U.L. construction?*

**Determine the general location of the operator, attachment points, and solar panel (if used).**

- 1. Is there a suitable location for the operator?*
- 2. Can the solar panel (if used) be mounted in an unobstructed area facing south (in the northern hemisphere)?*
- 3. Will additional solar panel cable be required?*
- 4. Is electricity available (if required)?*

**Consider safety and access options. Recommend if needed.**

- 1. Will there be children or animals in the area?*
- 2. Are safety loops, edge switches, or photo beam detectors required?*
- 3. How can the gate be opened in emergencies?*
- 4. How will visitors enter and exit?*
- 5. Will vehicles (and trailers) have sufficient room off roadway to operate any control devices such as keypads?*

# PARTS IDENTIFICATION

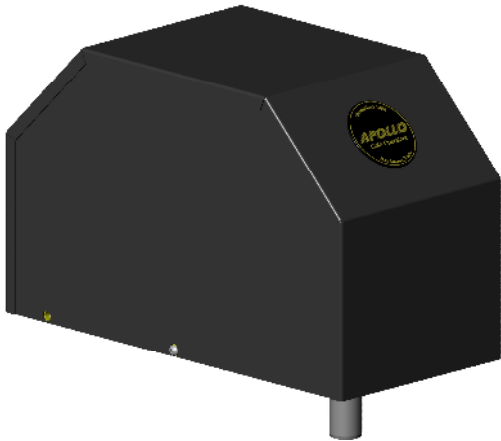

Operator

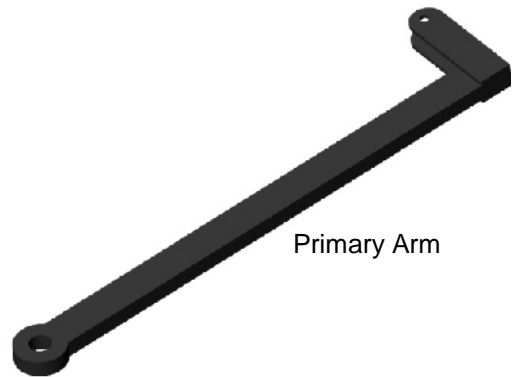

Primary Arm

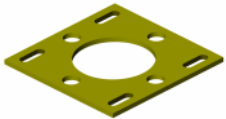

Mounting Plate



Adjustable Arm

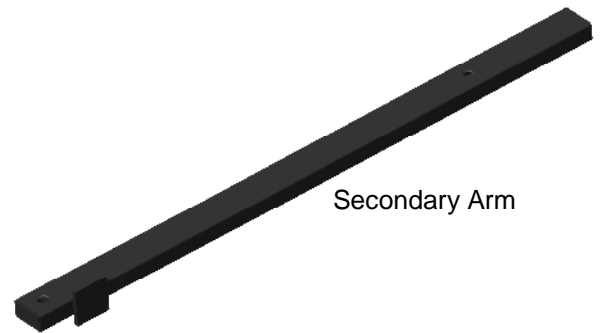

Secondary Arm



Control Box

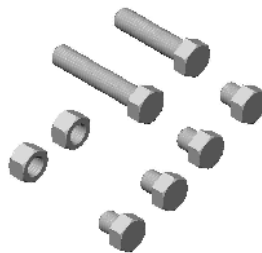

Fasteners



Gate Bracket



CAUTION Signs (2 each)

# POST LOCATION GUIDE

Determine the angle that the gate will open to (**A**). Select the post coordinates (**B&C**) as shown on the chart below. Distances are from the hinge square to the center of the mounting post. Longer gates should operate at the longer speeds.

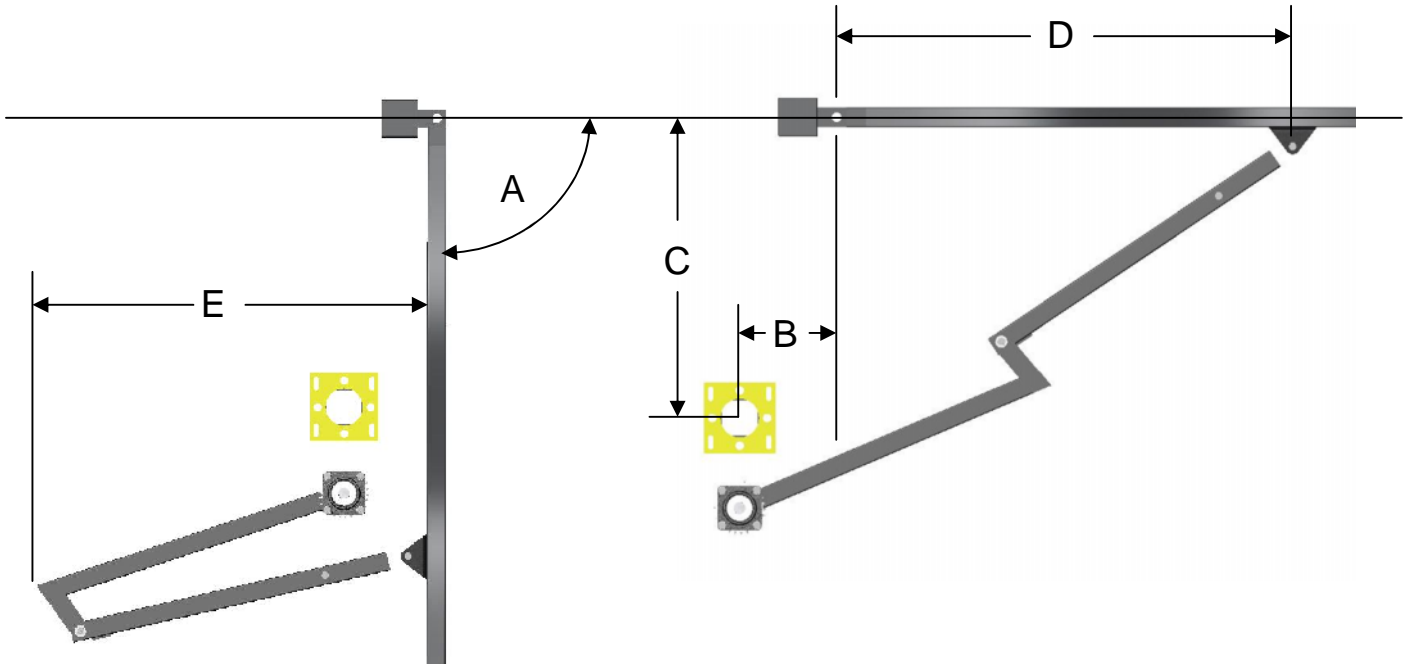

A Open degrees	B inches	C inches	D inches	E inches	Approximate Seconds to open
90°	10	31.2	46.3	40.6	15
90°	10	30	47.1	42	16
92°	15	30	42.1	34	12
97°	13.5	25.5	46.3	46.8	17
97°	15	25	45	47.1	16
100°	20	25	40	43.7	13
107°	20	20	42.4	53.5	17
110°	25	20	37.4	50.6	13
116°	25	15	39.3	58.4	16
117°	20	15	44.3	50.3	20

Optimum

# OPERATOR INSTALLATION

**STEP 1** The 3500 operator is designed for installation using a 4" x 4" square post (not supplied) with 1/4" wall thickness.

1. Determine the height on the gate where the operator will attach to.
2. Install the post as per the diagram below. The top of the post should be 2" above the centerline of the location where the gate bracket will be mounted on the gate. Gate bracket should be mounted to a structural member on the gate. Do not attach the gate bracket to pickets.
3. **Conduit should be considered at this time for cable routing from control box to operator.**

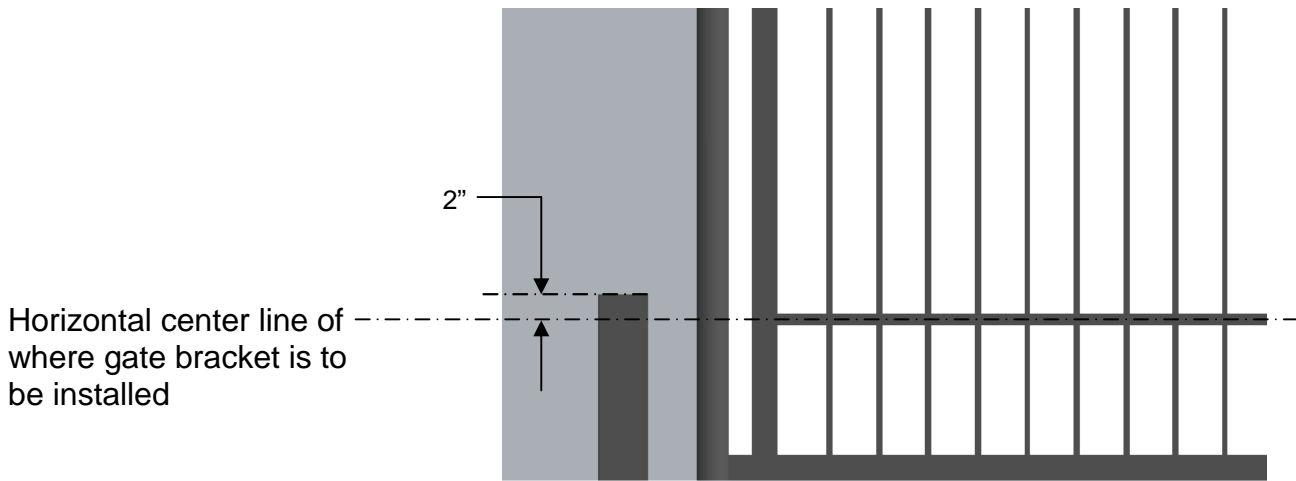

**IMPORTANT:** The mounting post should be square to the gate in the closed position and level for proper operation.

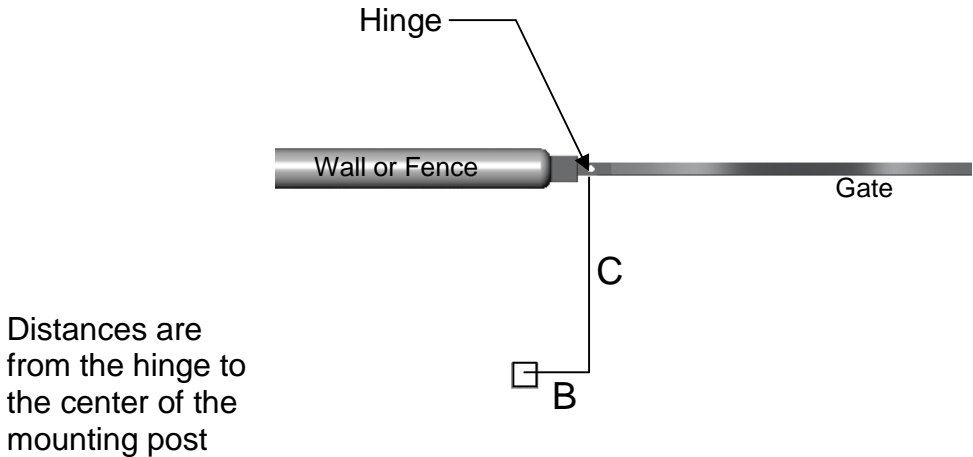



## STEP 2

Mount the control box as close to the operator as possible (recommended within 5 feet). Use mounting hardware capable of supporting the weight of the control box with the battery installed.

**Do not mount the control box where the person using the push button on the side of the box can come in contact with the gate.**

Set the battery inside of the control box with the terminals toward the front. *(Do not use batteries with side terminals.)*



## STEP 3

Weld the mounting bracket on top of the mounting post. The bracket should be level and square to the post.

Tack welds may be made from the top side of the bracket and post. Bottom welds should be made for permanent rigidity.



## STEP 4

Lay the operator chassis on it's side. The two ears on the primary arm should point toward the direction the gate will close. Install the primary arm to the main drive shaft using the 1/4" key stock and tighten both set screws. The collar on the primary arm should be installed on the shaft as far as possible.

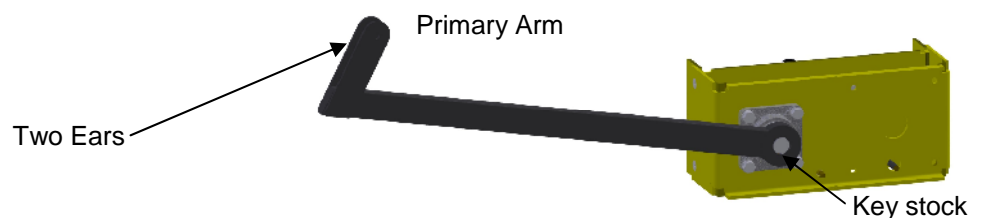

## STEP 5

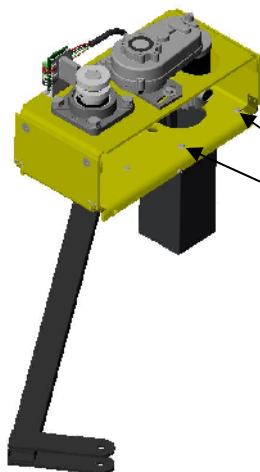

Install the drive unit on the mounting bracket using (4) 1/2" x 3/4" hex bolts and lock washers.

## STEP 6

Install the secondary arm to the primary arm using a 1/2" x 2-1/4" hex bolt, brass washers, and lock nut.

The stop tab should be positioned away from the gate.

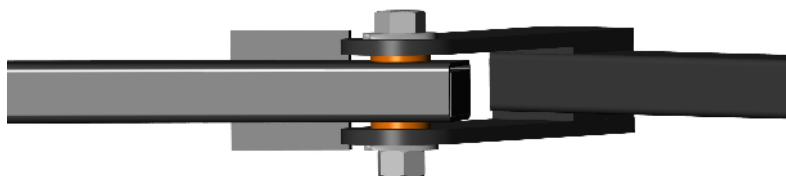
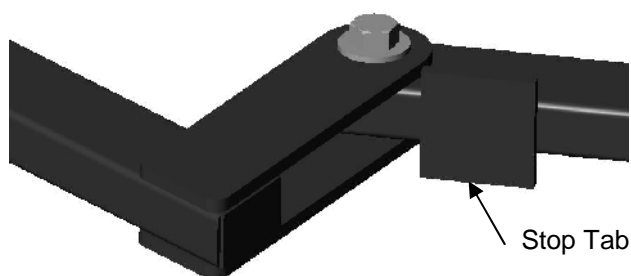

**STEP 7** Install the adjustable arms to the secondary arm using the 1/2" x 1-1/2" hex bolt and nut. Use the middle hole in the adjustable arm.

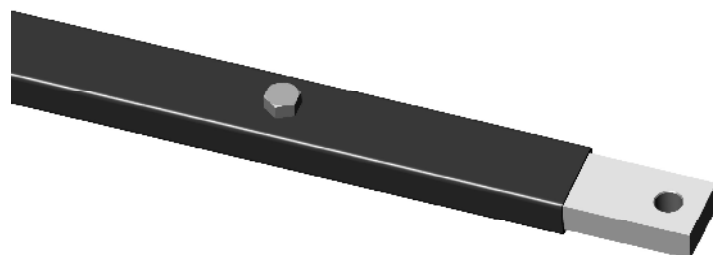

**STEP 7** Install the gate bracket to the adjustable arm using the 1/2" x 2-1/2" hex bolt, washers, and lock nut.

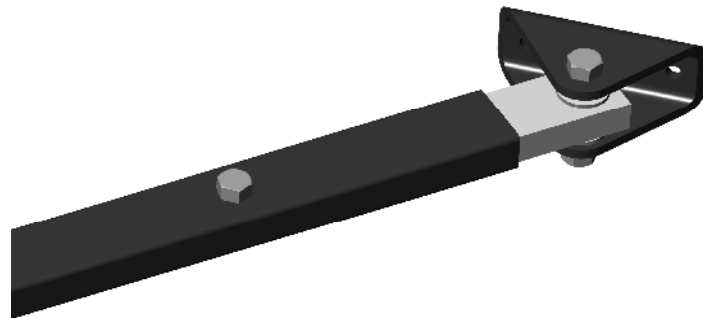

**STEP 8** Push the arms assembly up against the gate in the closed position. Make sure that the primary arm is locked into the stop tab on the secondary arm. Tack weld or c-clamp the gate bracket to the gate. Permanent welds or bolt attachment should be completed once limits are set.

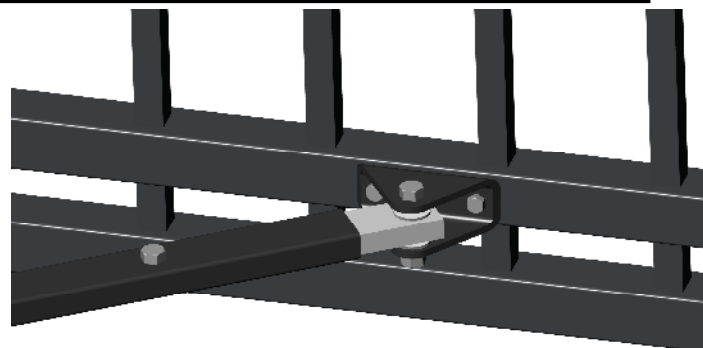

**STEP 9** Route the cable from the control box to the operator. Connect the cable to the left side of the terminal block on the operator as shown. The operator in this manual is set up for left side installation (from inside looking at gate in closed position). For right side installation plug the 5 pin connector into INPUT B on the surge board.

**Left Side Installation**

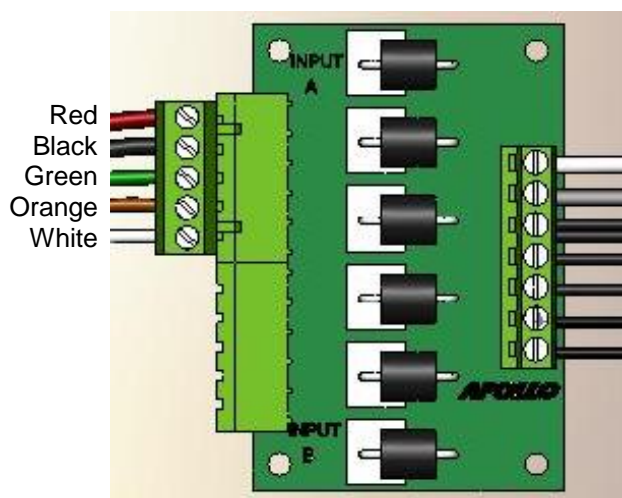

**Right Side Installation**

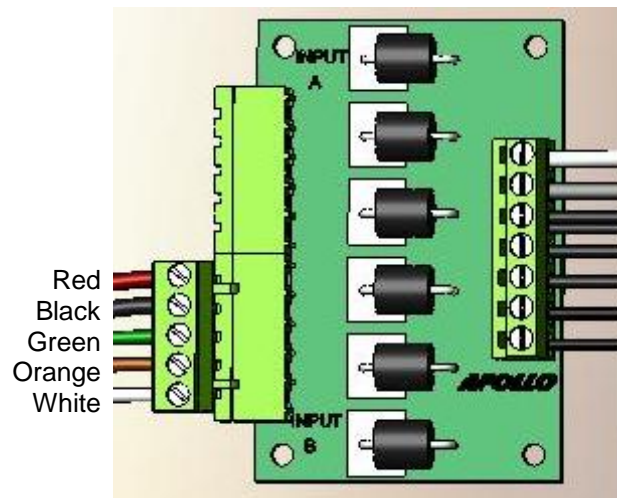

**STEP 10** Connect the two ring terminals on the connector end of the cable to the battery. The battery charger or solar panel should be installed at this time.

Plug the connector into the Master connector on the circuit board.

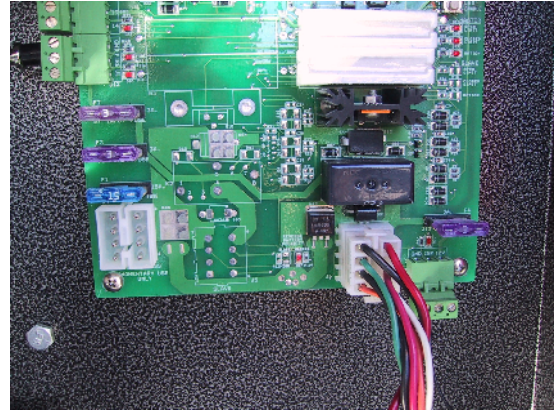
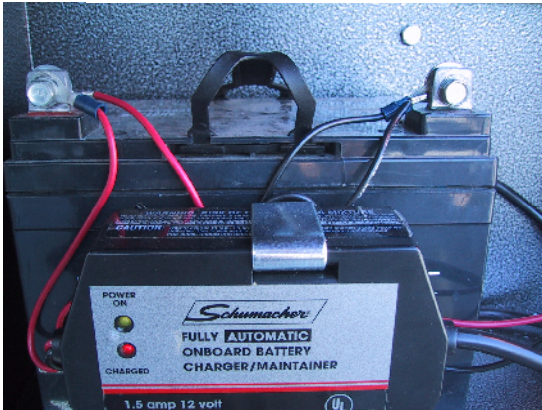

**STEP 11** Press LED Enable on the right side of the circuit board.

Turn program switch #1 off  
(TIMER TO CLOSE)

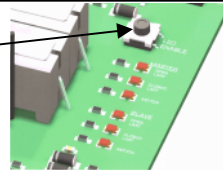

The gate should be in the closed position. Rotate the bottom collar until the **closed** LED illuminates. Open the gate to the desired open position and stop the gate. Rotate the top magnet collar until the **open** limit LED illuminates.

The close limit should be adjusted to allow the arms to lock over center but ensure that the close LED is illuminated when the gate stops.

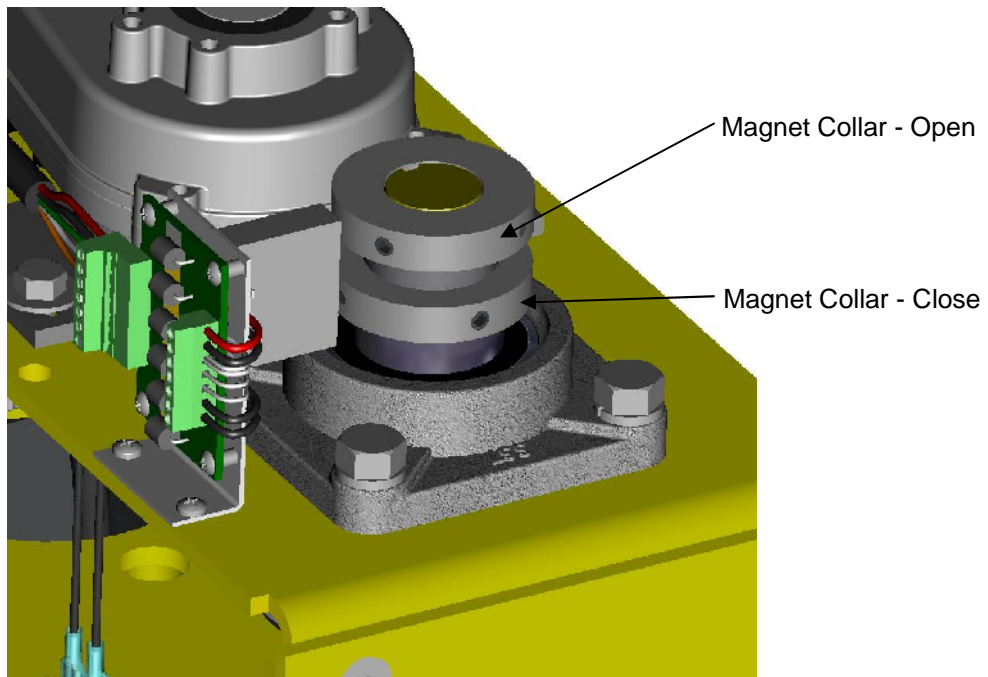

**STEP 12** The close tension on the gate can be further adjusted by:

Removing the 1/2" bolt on the secondary arm (course adjustment 1"-2").

Slide the adjustable arm out and rotate counter clockwise to increase close pressure and clockwise to reduce close pressure.

The three holes in the adjustable arm will allow further adjustment if necessary.

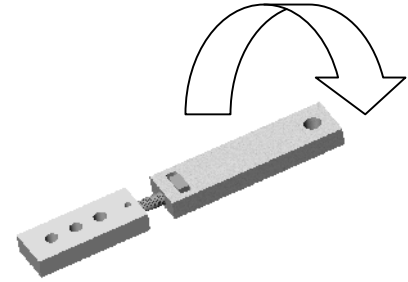

**EMERGENCY MANUAL OPERATION**

For manual operation, flip the release switch on the left underside of the operator.

Pull the arms enough to disengage the lock tab and open the gate.

The release switch should be reset for normal operation.



Or

**unplug the cable from the control box and plug into the emergency bypass connector**

**EMERGENCY BYPASS (for emergency opening only)**

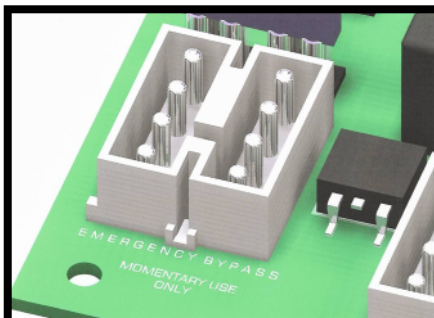

Applies battery voltage directly to motor to open gate if control board fails. User must unplug before gate opens to maximum travel or motor will continue to run until it stalls.

## STEP 13 Programming Current Sensing

The **835/836** control boards incorporate a safety feature that will put the operator into a hard shutdown mode if the control board detects a current sense two consecutive times during a cycle. This hard shutdown condition can only be reset by shorting the **FIREBOX** or **UL** connectors on the left side of the control board to ground. This condition may also be reset by pressing the **HARD SHUTDOWN RESET** button located toward the upper right hand corner of the control board. If a firebox is used in the installation, The firebox door (optional) should be opened and closed to reset the control board.

The following instructions must be followed at installation for proper safety assurance. All limits should be set before beginning this procedure.

This new procedure applies to revision **31** or higher firmware.

1. Press and hold the **LED ENABLE** button for five seconds and then release. The **STOP LED** will blink indicating that the board is in learn mode.
3. Cycle gate for 3 full cycles. The **STOP LED** will stop blinking indicating that the board is now ready for normal operation
4. Test the auto reverse sensitivity to ensure maximum safety protection. The current sensitivity adjustment pot may be adjusted to decrease or increase sensitivity.

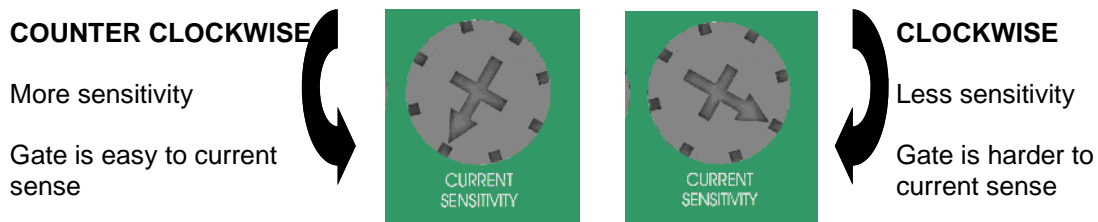

8. Refer to the **835/836 Operator Control Board Manual** to set other options such as program switch options and close timer adjustments.

Installation is now complete.

# 835/836 Control Board Parts Identification

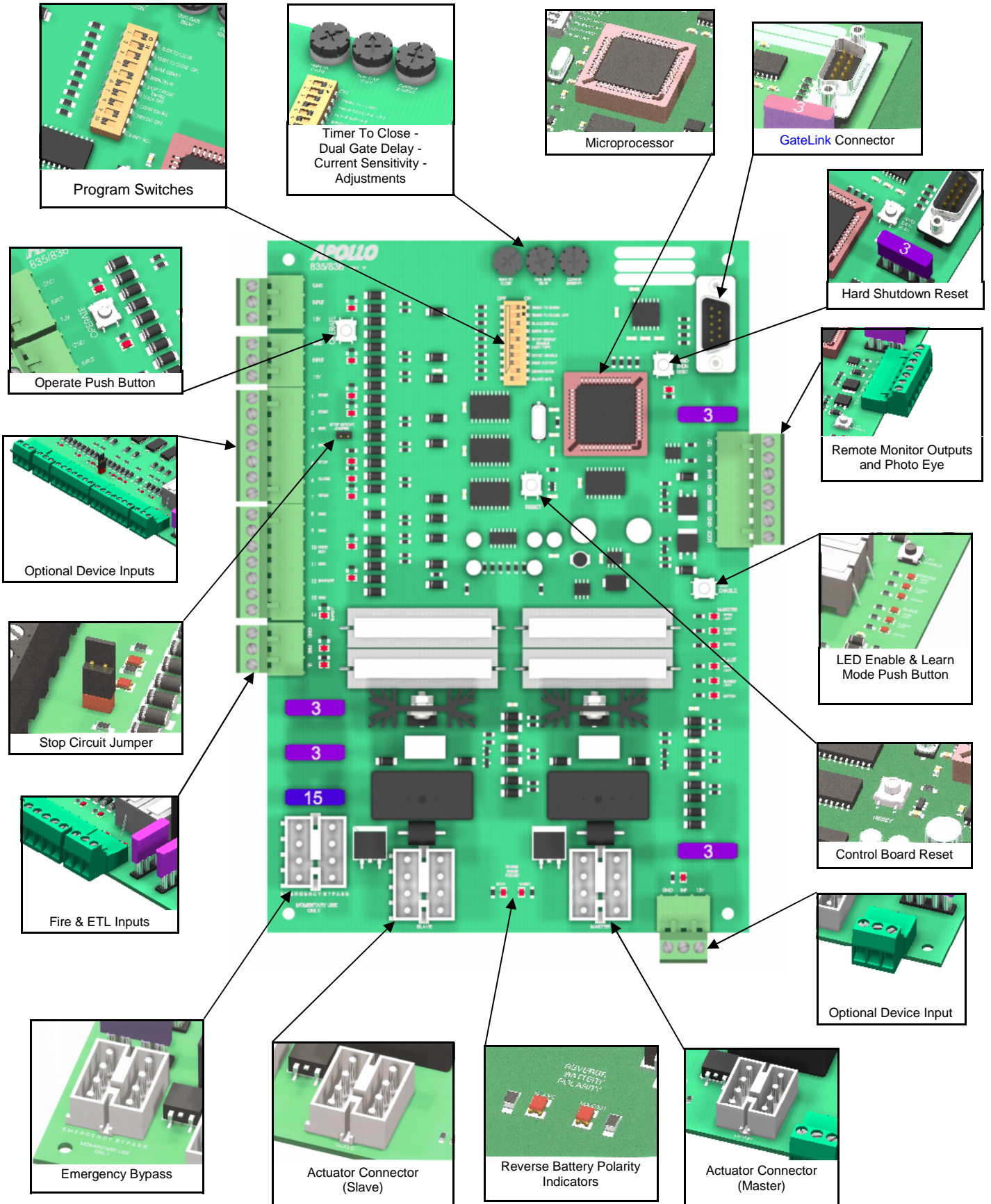

## Actuator Connector

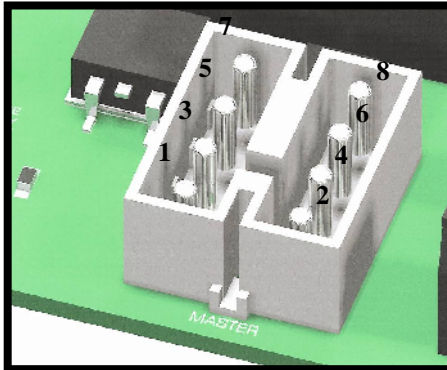





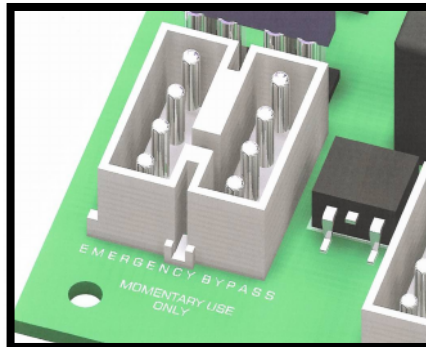

Board	Actuator Cable	Function
Pin 1	Orange	Open Limit
Pin 2	White	Close Limit
Pin 3	Black	Motor (positive on open, negative on close)
Pin 4	Red	Motor (negative on open, positive on close)
Pin 5	Green	Common for both limit switches
Pin 6	Yellow	Feedback from intelligent actuator(816E/816EX)
Pin 7	Black	Battery Negative
Pin 8	Red	Battery Positive

## EMERGENCY BYPASS (open only)



Applies battery voltage directly to motor to open gate if control board fails. User must unplug before gate opens to maximum travel or 15 amp fuse will open. Fuse should be checked before returning gate to service.

## Remote Outputs and Photo Eye Hookup

	<b>12V</b>	Supplied battery voltage
	<b>MAS</b>	Master Operator Indicator (indicates master side of gate is closed) +12V when on closed limit. Ground when off of closed limit.
	<b>SLV</b>	Slave Operator Indicator (indicates slave side of gate is closed) +12V when on closed limit. Ground when off of closed limit.
	<b>GND</b>	Battery supplied ground
	<b>SIREN</b>	Connect to siren + applies +12V when gate(s) are running, or in hard shutdown
	<b>GND</b>	Battery supplied ground
	<b>LOCK</b>	Connect to lock + (optional) Magnetic or Solenoid type locks (Dip Switch #6 Selectable)

## Photo Eye Hookup



Photo eye / safety loop wiring. Connect the positive power wire of the accessory to 12V. Connect the ground wire of the accessory to MAS (upper right area of the 835/836 board). Connect the relay wires of the accessory as normal: COM to GND. NO to SAFETY (#14) (for a safety device). When the gate operator begins opening (comes off of the closed limits) the MAS terminal will become a ground and will complete the flow of power to the accessory. This will power the accessory up and it will work as normal until the gate gets closed and the MAS terminal switches and the device will power down.



## Adjustments

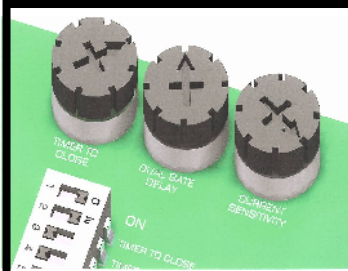

**TIMER TO CLOSE** Adjusts time before gate automatically closes. Adjustable 5 to 70 seconds.

**DUAL GATE DELAY** Adjusts delay between master and slave operation 0-4 seconds (836 only with magnetic, solenoid, and other locking devices)

**CURRENT SENSITIVITY** Increases or decreases the Auto Reverse sensitivity.

## Push Buttons

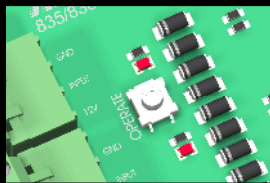

**OPERATE** When depressed, activates the gate. Used for initial installation and testing.



**Hard Shutdown Reset** Resets the operator when the gate current senses twice before fully opening or closing.

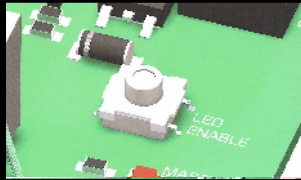

**LED ENABLE** When depressed, activates LEDs for 15 minutes to assist in installation and troubleshooting.

Hold the push button down for five seconds to put the board in program mode.

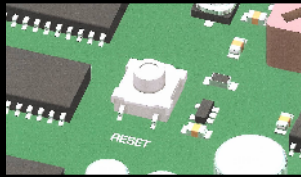

**RESET** Resets the microprocessor. Returns processor to last known state.

## Jumpers

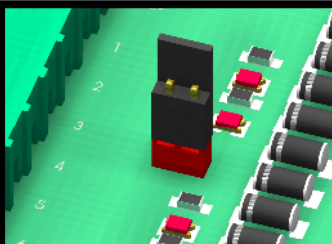

**STOP CIRCUIT JUMPER** When the STOP CIRCUIT JUMPER is connected, the gate will operate normally.

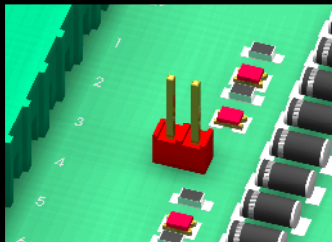

**STOP CIRCUIT JUMPER** When a 3-button station is connected to the board, the STOP CIRCUIT JUMPER must be removed.

# Program Switches

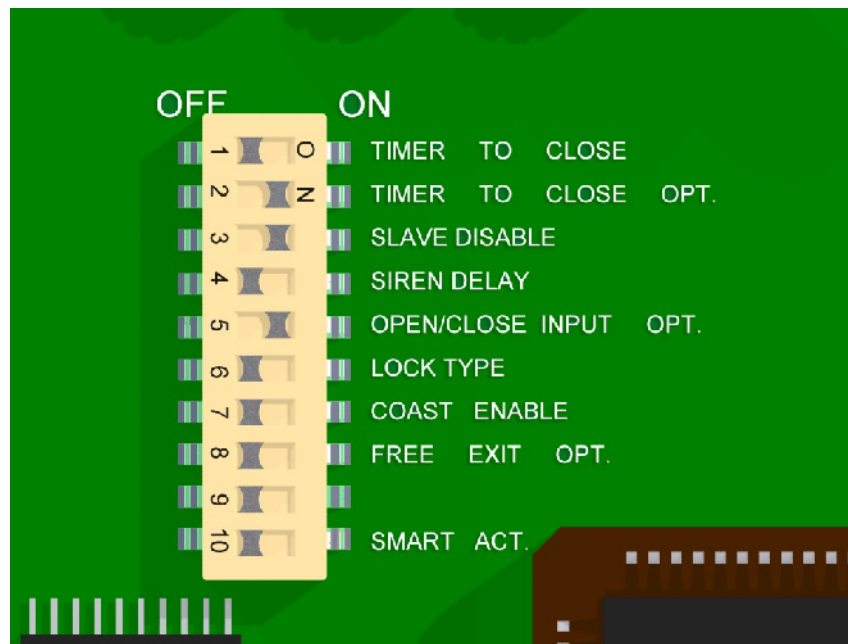





## OFF

## ON

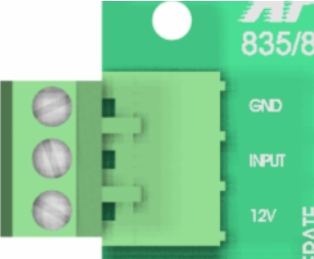
<b>1 TIMER TO CLOSE</b>	Gate does not automatically close.	Gate automatically closes.
<b>2 TIMER TO CLOSE OPT.</b>	Gate automatically closes from any position after opening.	Gate automatically closes only when completely open (open limit engaged).
<b>3 SLAVE DISABLE</b>	Enables slave side (dual gate use).	Disables slave side. (single gate use)
<b>4 SIREN DELAY</b>	Siren (optional) active when gate is moving.	Siren (optional) starts 5 seconds before gate moves.
<b>5 'STOP' CIRCUIT ENABLE</b>	Must hold down open or close buttons to move gate. Gate stops when button released.	Normal operation Momentary open or close input runs gate to limit.
<b>6 LOCK TYPE</b>	For 12V mechanical (solenoid) locks. (+12V for 4 seconds on open cycle)	For 12V magnetic locks. (+12V when on close limit)
<b>7 COAST ENABLE</b>	Gate will brake when at Open or Close limit	Gate will coast (minimally) when it reaches limits.
<b>8 FREE EXIT OPT.</b>	A free exit input will open gate from closed position or after a close cycle only.	A free exit input will open gate from any position after an open or close cycle.
<b>9 NOT USED</b>		
<b>10 SMART ACT.</b>	Off for 416E & 416EX actuators, slide gates, 3500 or when slow down feature is not desired.	Used for 816E & 816EX actuators only (soft start & stop).

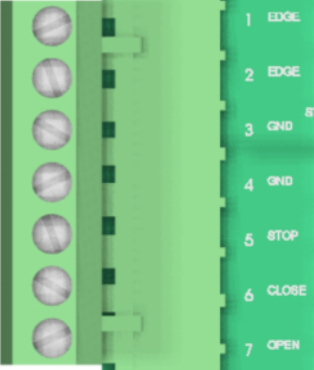
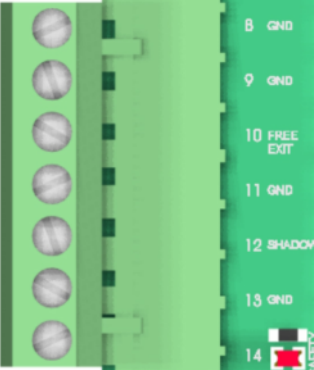
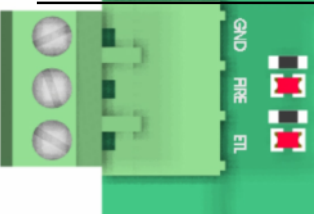
# Optional Device Inputs

	835/8 GND	<b>GND</b>	Supplied Battery Ground
	INPUT	<b>INP</b>	Activate Gate (Push button activation when momentarily shorted to ground)
	12V	<b>12V</b>	Supplied Battery Voltage (Protected with 3 Amp fuse)
	GND	<b>GND</b>	Supplied Battery Ground
	INPUT	<b>INP</b>	Activate Gate (Push button activation when momentarily shorted to ground)
	12V	<b>12V</b>	Supplied Battery Voltage (Protected with 3 Amp fuse)
	1 EDGE	<b>EDGE</b>	Reverse edge input. When grounded, will stop and reverse gate if closing, resets close timer if gate is open.
	2 EDGE	<b>EDGE</b>	Reverse edge input. When grounded, will stop and reverse gate if closing, resets close timer if gate is open.
	3 GND	<b>GND</b>	Supplied Battery Ground
	4 GND	<b>GND</b>	Supplied Battery Ground
	5 STOP	<b>STOP</b>	Stop input from a 3 button station (must remove STOP CIRCUIT JUMPER) Normally closed
	6 CLOSE	<b>CLOSE</b>	Close input from a 3 button station (see program switch #5 for options)
	7 OPEN	<b>OPEN</b>	Open input from a 3 button station (see program switch #5 for options)
	8 GND	<b>GND</b>	Supplied Battery Ground
	9 GND	<b>GND</b>	Supplied Battery Ground
	10 FREE EXIT	<b>FREE EXIT</b>	Opens gate if closed, stops and reverses gate if closing, resets close timer if gate is open.
	11 GND	<b>GND</b>	Supplied Battery Ground
	12 SHADOW	<b>SHADOW</b>	Resets close timer when gate is open (also referred to as under gate loop)
	13 GND	<b>GND</b>	Supplied Battery Ground
	14 SAFETY	<b>SAFETY</b>	Resets close timer if gate is open, stops and reverses if gate is closing. (Does not open a closed gate)
	GND	<b>GND</b>	Supplied Battery Ground
	FIRE	<b>FIRE</b>	When grounded, opens gate and holds gate open until released. Clears "Hard Shutdown" mode of software.
	UL	<b>UL</b>	When grounded, opens gate and holds gate open until released. Clears "Hard Shutdown" mode of software.

	GND	<b>GND</b>	Supplied Battery Ground
	INPUT	<b>INP</b>	Activate Gate (Push button activation when momentarily shorted to ground)
	12V	<b>12V</b>	Supplied Battery Voltage (Protected with 3 Amp fuse)

## 911 Siren

The 911 Siren is included with all Apollo ETL Gate Operators.

Mount siren in an area that will produce maximum performance (additional wire may be required).

Connect the red wire to the SIREN connector on the Remote Monitor Output Connector block.

Connect the black wire to the GND connector on the Remote Monitor Output Connector block.

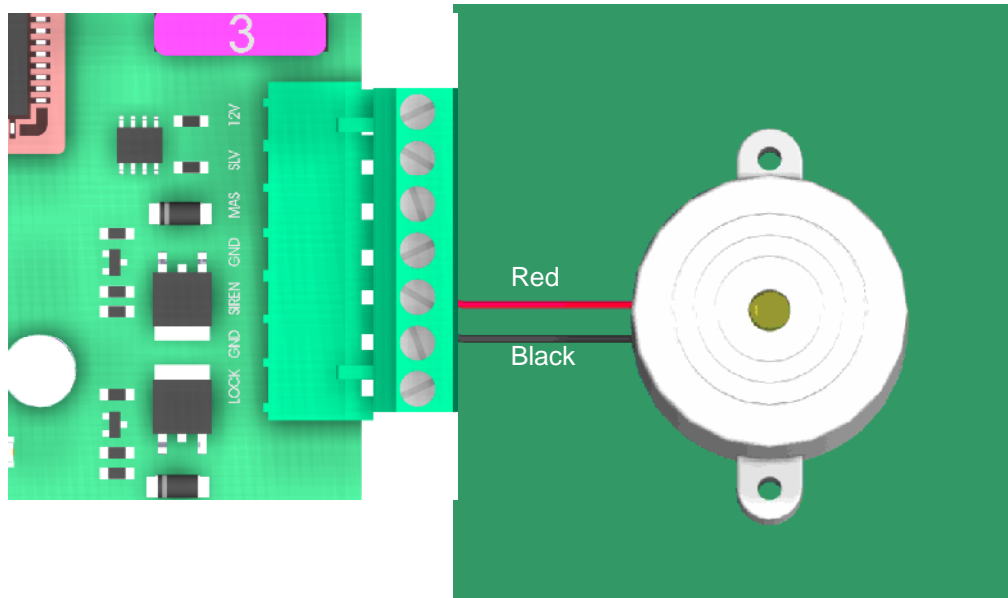

Set Program Switch # 4 as preferred:

**ON** - Upon activation, Siren will start for 5 seconds before gate(s) begin moving.

**OFF** - Siren and gate(s) start immediately upon activation.

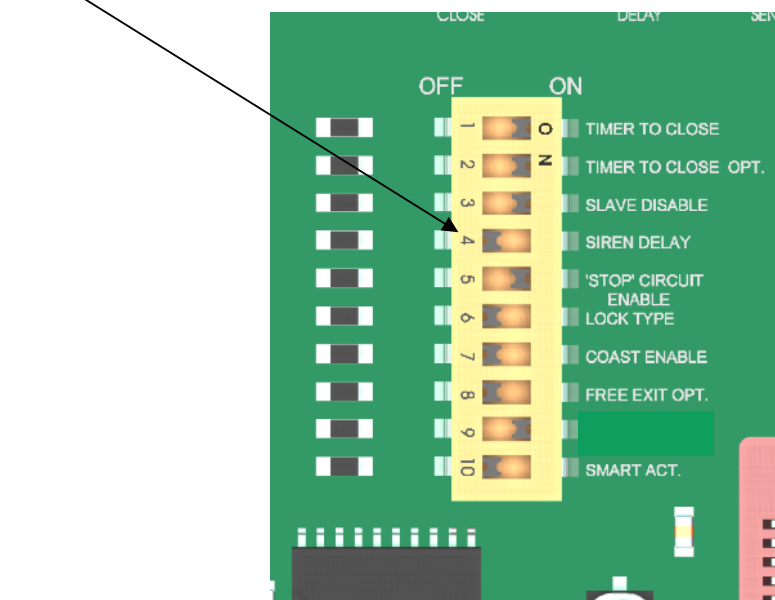

# APOLLO *Gate Operators* RECEIVER OPTIONS

Do not confuse the receiver code switches with the red program switches on the gate control board.

Never set all code switches to the same position. Transmitters must match code switches for proper operation.

If power is taken directly from battery or connected as shown below, receiver should be configured for 12VDC

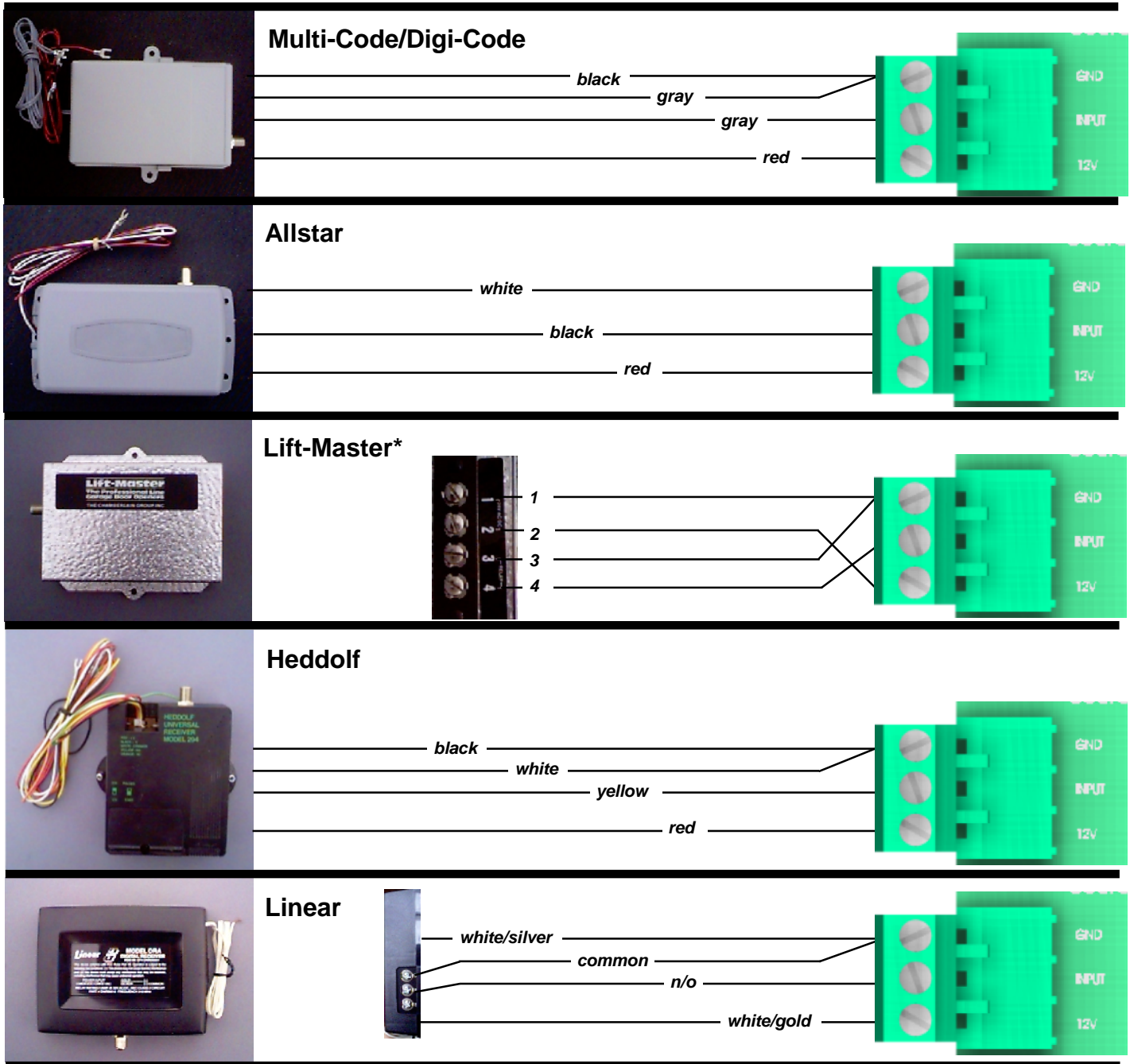

\* Lift-Master will require that the 12/24 jumper be set to 12 and the C/M (constant/momentary) jumper be set to C

# TROUBLESHOOTING OPERATOR & ACCESSORIES

Some troubleshooting will require a hand held multimeter. An inexpensive digital multimeter may be purchased at Radio Shack or a local electric supply company. Refer to the owners manual for instructions.

## **SYMPTOM** *Gate opens OK but after closing, opens back up.*

1. Excessive closing pressure on gate. Re-adjust the close limit switch on the operator.
2. Automatic reverse sensitivity is set too sensitive. Re-adjust - **CAUTION: Automatic reverse sensitivity should be set sensitive enough to avoid injury.**
3. Gate is mechanically binding. Disconnect operator from gate and eliminate binding.
4. Battery voltage is too low. Battery voltage should be 12 to 14 volts under load. Check solar panel output or battery charger output or re-evaluate usage.
5. Replace circuit board.

## **SYMPTOM** *Gate moves only a few feet, then stops or reverses.*

1. Battery voltage is too low. Battery voltage should be 12 to 14 volts under load. Check solar panel output or battery charger output or re-evaluate usage.
2. Verify that program switch #10 is off
3. Gate is mechanically binding. Disconnect operator from gate and eliminate binding.
4. Current sensitivity is adjusted too sensitive. Re-adjust current sensitivity.
5. Re learn the circuit board by holding down the LED Enable push button for 5 seconds and cycle gate until LEDs stop blinking.
6. Replace circuit board

**SYMPTOM** *Gate will open using push button on side of box, but not with transmitter.*

1. Code switches do not match. Check that the code switches in the transmitter and the receiver match.
2. Low or dead battery in transmitter. Replace battery.
3. Fuse blown on circuit board. Check fuses on gate control board.
4. Low battery in operator. Battery voltage should be 12 to 14 volts under load.
5. Replace receiver.

**SYMPTOM** *Transmitter works, but not very far.*

**Note:** *Transmission distances will vary according to terrain, obstructions, and electrical interference. The normal range from inside a vehicle is 50-100 feet while 100-150 feet may be obtained from outside the vehicle.*

1. Low battery in transmitter. Replace battery.
2. Transmitter malfunctioning. Try a different transmitter.
3. Antenna not making good connection. Be sure center conductor of antenna is penetrating the female connector on the side of the gate box.
4. Reception is being blocked. Raise the height of the antenna using a #244 antenna extension kit.
5. Replace receiver.

**SYMPTOM** *Gate randomly opens, closes, or stops for no reason.*

1. Transmitter is stuck on. Check all transmitters, keypads, pushbuttons, etc. for a stuck button.
2. Transmitter and receiver code switches are all down, up, or in the middle. Change at least one switch position in the transmitter and receiver.
3. Push button on side of control box is defective. Disconnect and test.

**SYMPTOM** *Gate will not open or close.*

Short the GND and UL connections on the lower left set of connectors and test.

Disconnect the solar panel or charger and measure the battery voltage. Battery should read 12 or more volts and never drop below 11 volts when gate is operating.

Reset program switches to factory settings. .

**Single Boards**

# 1, # 2, # 3, # 5, # 9, **ON**, all others **OFF**

**Dual Boards**

# 1, # 2, # 5, # 9 **ON**, all others **OFF**

**\*Be sure to turn Switch # 9 OFF during normal operation.**

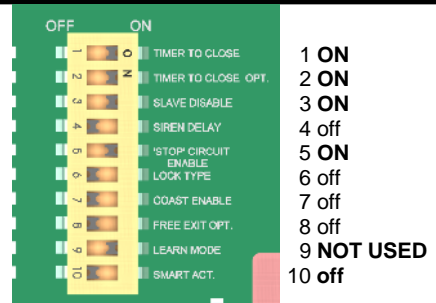

Disconnect all accessories from the circuit board - receivers, push buttons, keypads, loops, phones, intercoms, etc.

Activate the operator by momentarily shorting **GND** to **INP** on one of the three pin connectors.

If the operator works, reconnect each accessory individually starting with push button and test operation.

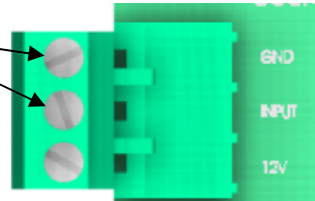

Disconnect operator from circuit board and inspect pins in the connector for damage or poor connections.

Check for proper limit switch configuration (multimeter required) on the cable from the operator to the control box:

**GATE IN OPEN POSITION** .....Orange & Green wires are shorted, White & Green wires are open.

**GATE IN CLOSED POSITION** ..White & Green wires are shorted, Orange & Green wires are open.

**GATE IN MID TRAVEL**..... White, Green, & Orange wires are open, no shorts.

Replace circuit board.





## LIMITED TWO-YEAR WARRANTY

Apollo Gate Operators are warranted against defects for a period of 24 months from the date of purchase, providing recommended installation procedures are followed. This warranty is in lieu of all other warranties expressed or implied (some states do not allow limitations on how long an implied warranty lasts, so this limitation may not apply to you) and shall be considered void if damage was due to improper installation or use, connection to improper power source, or if damage was caused by fire, flood, or lightning. The manufacturer will not be responsible for any labor charges incurred in the removal or replacement of defective parts.

In case of failure due to defective material or workmanship during the warranty period, the defective part will be repaired or replaced at the manufacturer's option at no charge if returned freight prepaid. New or factory rebuilt replacements may be used. Replacement parts are warranted for the remaining portion of the original warranty period. The manufacturer will pay standard ground freight on the return of repaired or replaced items in warranty.