

APOLLO

Gate Operators, Inc.

400 Upgrade Kit

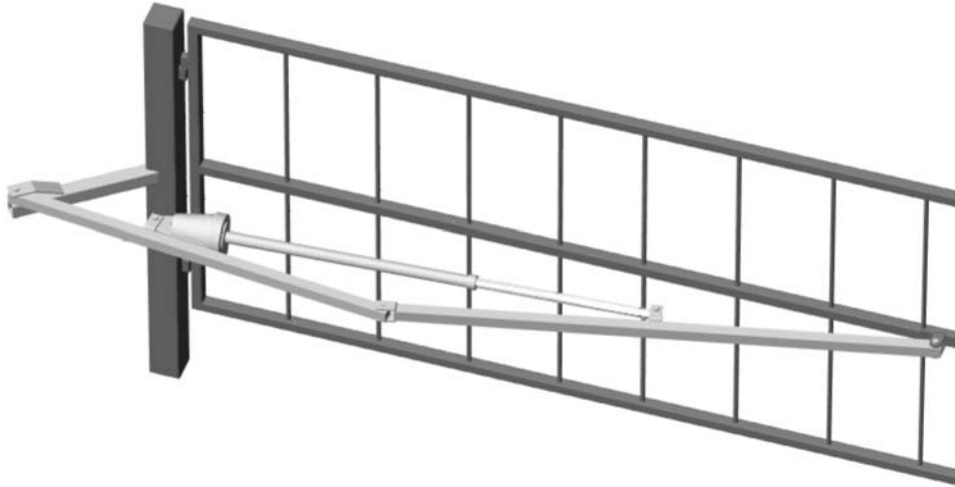

Parts Identification

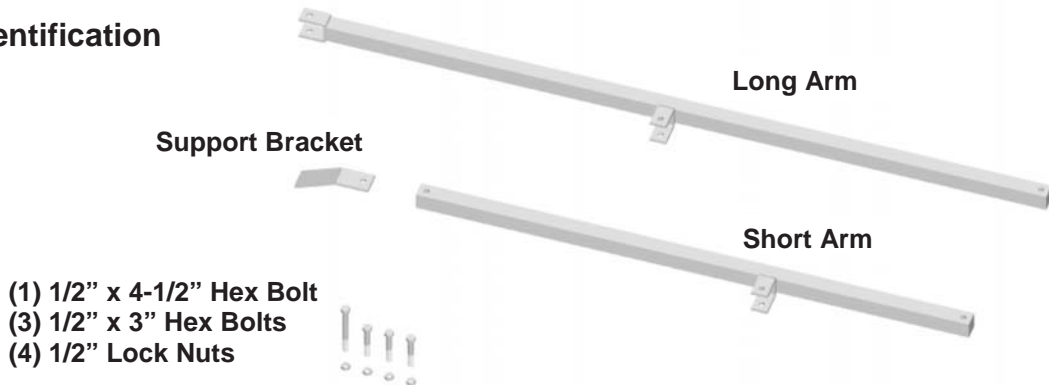

STEP 1 Location of Pivot Point

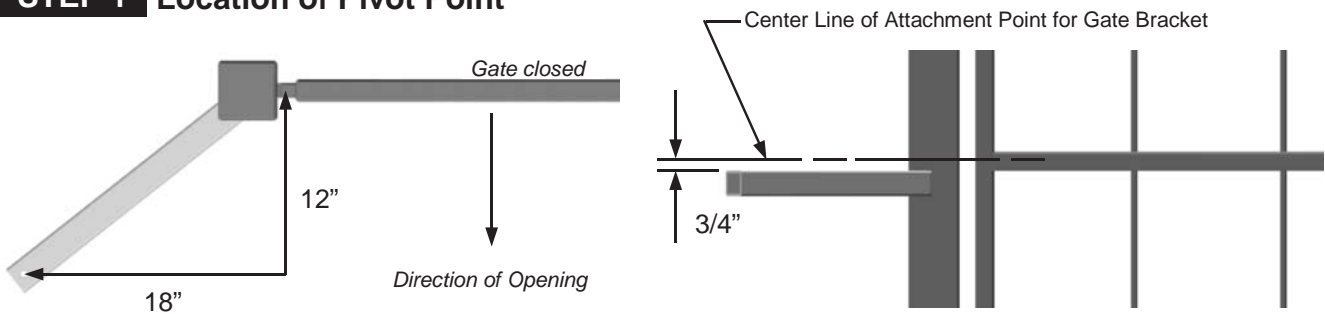

Weld the pivot arm to the hinge post or other solid surface using the dimensions shown. Pivot arm must be level for proper operation.

STEP 2 Short Arm Installation

Mount short arm to pivot arm as shown

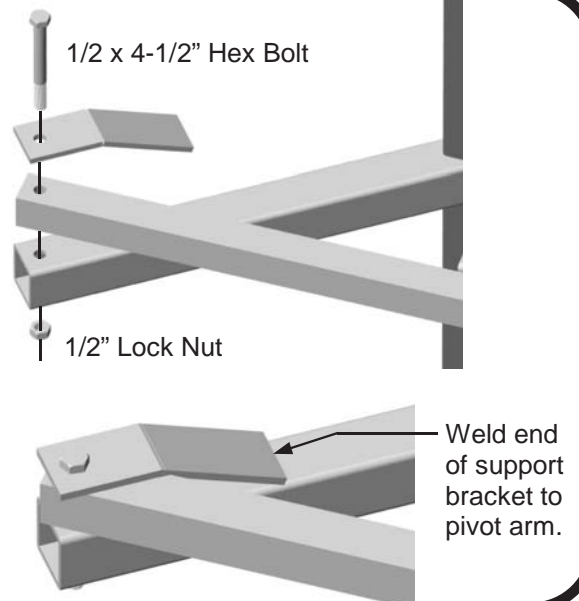
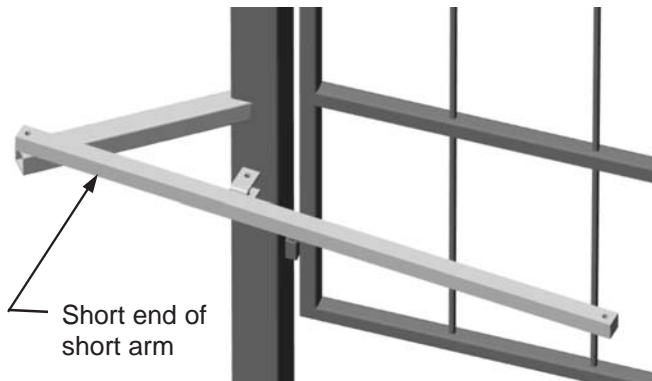

STEP 3 Long Arm & Actuator Installation

Mount the long arm and actuator to the short arm as shown. Actuator should be extended.

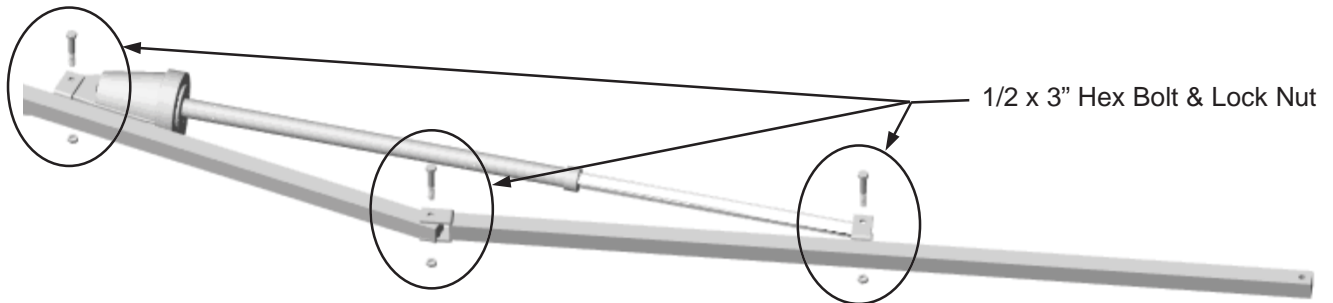

STEP 4 Attachment to Gate

Align the end of the long arm to the gate and mount the gate bracket. Limits may now be adjusted as per the 1500/1600 Installation manual. Be sure the arms have sufficient clearance when open.

All hardware should be tightened to allow free movement with minimum vertical play.

The gate bracket mounting location should be approximately 8 feet from the center of the hinge to the center of the gate bracket.

