

Vehicular Swing Gate Operator

Nice
Gate Operators

Titan
912L



The Titan 912L Gate Operator is intended for use with vehicular swing gates. The Titan 912L Gate Operator can be used in Class I, Class II and Class III applications.

This page intentionally left blank.

TABLE OF CONTENTS

CAUTIONS AND NOTES	1	5 - INSTALLATION PROCEDURES	5
EXTREMELY IMPORTANT	1	5.1 - Pivot arm installation	5
DEFINITIONS COMPLIANT TO UL325	1	<i>Figure 5-1 PULL TO OPEN INSTALLATION</i>	5
1- OVERVIEW	1	<i>Figure 5-2 VERTICAL PIVOT POSITION</i>	5
1.1 - Titan Swing Gate Opener	1	5.2 - Push to open installation	6
1.2 - Titan Swing Gate Opener Specifications	1	<i>Figure 5-3 PUSH TO OPEN INSTALLATION</i>	6
2 - GATE INFORMATION	1	5.3 - Actuator mounting	6
2.1 - ASTM F2200	1	<i>Figure 5-4 ACTUATOR MOUNTING</i>	6
2.2 - Gate latches	2	<i>Figure 5-5 GATE BRACKET MOUNTING</i>	6
2.3 - Specific applications	2	5.4 - Manual release/manual operation	7
2.4 - Swing gates	2	<i>Figure 5-6 MANUAL RELEASE DISENGAGE</i>	7
2.5 - General requirements	2	<i>Figure 5-7 MAUAL RELEASE RE-ENGAGE</i>	7
3 - SAFETY AND CAUTIONS	2	5.5 - Titan actuator wiring	8
3.1 - Properly installed safety devices	2	<i>Figure 5-8 MAUAL RELEASE HANDLE</i>	8
3.2 - Safety signs, notices to personnel warning signs	2	<i>Figure 5-9 WIRE HARNESS INSERTION</i>	8
3.3 - Gate system safety devices	3	<i>Figure 5-10 TITAN ACTUATOR WIRING</i>	8
3.4 - Infrared beams and warning signs	3	5.6 - Control board wiring	9
3.5 - Establish the location	3	<i>Figure 5-12 WIRING DIAGRAM FOR 936 CONTROL BOARD</i>	9
3.6 - Read and follow all instructions	3	5.7 - Limit switch adjustment	10
3.7 - Keep children away	3	<i>Figure 5-13 LIMIT SWITCH ADJUSTMENT</i>	10
3.8 - Test the gate system	3	<i>Figure 5-15 LIMIT LED LOCATION 936 CONTROL BOARD</i>	10
3.9 - Keep gates properly maintained	3	6 - GENERAL LAYOUT AND SAFETY ACCESS	11
4 - PRE-INSTALLATION NOTES	3	<i>Figure 6-1 LAYOUT FOR IN- GROUND LOOPS</i>	11
4.1 - Follow instructions	3	<i>Figure 6-2 LAYOUT FOR PHOTOCELLS</i>	11
4.2 - Intended usage	3	7 - ACCESSORIES AND SENSORS	12
4.3 - Warnings, cautions and notes	3	8 - INSPECTION AND OPERATION	13
		9 - EMERGENCY VEHICLE ACCESS	13

CAUTIONS AND NOTES

This instruction manual is intended to aid the installer in the overall process of correct installation at the desired location. Periodically, the manual will illustrate "warnings, cautions and notes" which are items the installer should carefully read to prevent damage to the gate, gate system or personal injury to yourself or others.

EXTREMELY IMPORTANT

Anyone who installs, assists with installation or otherwise facilitates the installation in any manner should thoroughly read and understand this manual in its entirety before any attempt is made to actually begin the installation process.

DEFINITIONS COMPLIANT TO UL325

- Vehicular Swing-Gate Operator (or system) - A vehicular gate operator (or system) that controls a gate which swings or rotates in a direction that is intended for use for vehicular entrance or exit to a drive, parking lot, or the like.
- Gate - A moving barrier such as a Swinging, sliding, raising, lowering, rolling, or like barrier that is a stand-alone passage barrier or is that portion of a wall or fence system that controls entrance and/or egress by persons or vehicles and completes the perimeter of a defined area.
- Residential Vehicular Gate Operator - Class I - A vehicular gate operator (or system) intended for use in a home of one to four single family dwellings, or a garage or parking area associated therewith.
- Commercial / General Access Vehicular Gate Operator - Class II - A vehicular gate operator (or system) intended for use in a commercial location or building such as a multi-family housing unit (five or more single family units), hotel, garages, retail store, or other buildings servicing the general public.
- Commercial / General Access Vehicular Gate Operator - Class III - A vehicular gate operator (or system) intended for use in an industrial location, loading dock area, or other location not intended to service the general public.

1 - OVERVIEW

This manual provides documentation for mechanical installation and electrical wiring of the Titan swing gate operator with the Nice-brand 1050 gate operator. The Titan swing gate opener is intended for residential gate installations only. Please consult your Nice distributor or Nice dealer/installer for more information regarding installations or questions not specifically covered in this manual.

1.1 - Titan Swing Gate Opener

The Titan 912L swing gate operator delivers the next generation of easily installed, configured and maintained swing gate operators from Nice. With a maximum gate capacity of 600 lbs and 20 ft, this operator has a key lockable manual release, easily accessible limit switch settings as well as simple in-the-field maintenance and repair. The Titan gives dealers, installers and homeowners the ability to take control of their access and security systems. This operator includes a 2-year factory warranty against manufacturing defects and lifetime customer support.

1.2 - Titan Swing Gate Opener Specifications

Operator Specifications	912L (+12VDC)
Maximum Swing Gate Length	20ft.
Maximum Swing Gate Weight	600lbs.
Solar Compatible	Yes
Manual Release with Key-lock	Yes
Motor Encoder	Yes
Maximum Degree of Opening	120°
Easily Positioned Limit Switches	Yes
Drive Mechanism	Stainless Steel Screw
Operating Temperature	-4°F to 122°F
Weight	19.75lbs.
Dimensions - Fully Retracted	43"(L) x 4"(W) x 6.75"(D)
Push to Open Installation	Yes
Pull to Open Installation	Yes
UL 325 Certified/Listed	Yes

2 - GATE INFORMATION

2.1 - ASTM F2200

Gates shall be constructed in accordance with the provisions given for the appropriate gate type listed, refer to ASTM F2200 for additional gate types. Protrusions shall not be permitted on any gate, refer to ASTM F2200 for exceptions, if any.

Any non-automated gate that is to be automated in any manner should be upgraded to conform to the provisions contained within the provisions of this document and ASTM F2200 as applicable.

2.2 - Gate latches

In association with this gate actuator and this (these) swing gate(s), at no time should manual gate latches or locks be used. The forces applied to a swing gate by the actuator could be in excess to those forces which are safe for bystanders. Should unnecessary forces be applied to a gate system, such as a manual lock or impediment, catastrophic failure of the gate, actuator or control system could result in substantial damage, extensive physical injury or death.

2.3 - Specific applications

This swing gate actuator is intended for those locations where vehicle traffic is intended to be controlled through the use of an entryway obstruction (gate). The Titan 912L actuator is only to be used in conjunction with Nice brand control boards. If the gate, actuator and control system are not fully closed off from public access, the opening and closing of the gate system may result in severe damage, injury or death.

2.4 - Swing gates

Swing and slide gates are designed to move across an entry control point to prevent or allow controlled access by authorized persons or equipment. Swing or slide gate systems are not necessarily completely autonomous systems, and require regular maintenance and inspection on a periodic schedule. Although with certain safety devices in place the gate system could operate as a completely independent system free from human interaction for a defined period of time, human inspection and testing is required to ensure longevity and safe operation over long periods of time.

2.5 - General requirements

- Safety and security are obviously a number one priority for both the manufacturer and the end user. As a result this manual has been written to make all persons fully aware of the responsibilities required to ensure constant safety, security and longevity throughout the life of the system.
- The manufacturer of this swing gate system has performed countless hours of testing, analysis and statistical control analysis to ensure that this operator performs its intended function for extended periods of time. The installer should ensure and verify that all required safety devices are installed correctly and in a manner consistent with the requirements of this manual. Additionally, all devices, security devices, safety devices, sensors and other affiliated attachments are installed in a robust manner that will prevent their accidental damage, removal or incidental tampering.
- A basic requirement for this system to operate correctly is that at any time a sensor is triggered, covered, disconnected or otherwise tampered with, that the entire system ceases to function. If any part of the gate safety system is removed or triggered, an immediate safety action by the gate operator is expected (retraction or stoppage). If the gate safety system is not functional, or fails to operate within these guidelines, the gate should be immediately removed from service until repairs can be made.
- Any gate system that is open or has slats, bars or other material which allows an individual to stick their hands, head, or feet through the material, must be converted or covered in such a manner so as to prevent such future actions. Application of materials, and how to modify the gate system is up to the end user or installer, however care should be taken to prevent such human interaction into the moving gate system. No entry into the gate is ever authorized and should be prevented by whatever measures are required for that specific installation. Care should always be used during installation!
- Loops and loop detectors, photo-cells or other equivalent devices must be installed with this gate operator to prevent the gate from closing on vehicular traffic
- The speed limit for vehicular traffic through the gate area is 5 MPH. Install speed bumps and signs to keep vehicular traffic from speeding through the gate area. Failure to adhere to posted speed limits can result in damage to the gate, gate operator, and to the vehicle.
- Be sure that all residents are familiar with the proper use of the gate and gate operator. Be sure that all residents are familiar with the possible hazards associated with the gate system.
- Be sure that all warning signs are permanently installed on both sides of the gate in an area where they are fully visible to traffic
- It is your responsibility to periodically check all reversing devices. If any of these devices are observed to function improperly, remove the operator from service immediately and contact your installing or servicing dealer.

- Follow the recommended maintenance schedule of one inspection per every 180 days of use.
- Do not allow children to play in the area of the operator or to play with any gate-operating device.
- Be sure that all activating devices are installed a minimum distance of 8 feet away from the gate and gate operator, or in such a way that a person cannot touch the gate or gate operator while using the activating device. If activating devices are installed in violation of these restrictions, immediately remove the gate operator from service and contact your installing dealer.
- To remove the gate operator from service, operate the gate to the full open position, shut off power to the operator at the service panel, and disconnect batteries.



AUTOMATIC GATES ARE NOT FOR PEDESTRIANS!



Automatic gate openers are designed for vehicular traffic. They are powerful and can cause serious bodily injury or death. Accordingly, direct all pedestrian traffic to a separate walk-through gate.

3 - SAFETY AND CAUTIONS



WARNING

IMPORTANT SAFETY INSTRUCTIONS

WARNING - TO REDUCE THE RISK OF INJURY OR DEATH READ AND FOLLOW ALL INSTRUCTIONS.

- Never let children operate or play with gate controls. Keep the remote control away from children.
- Always keep people and objects away from gate. **NO ONE SHOULD CROSS THE PATH OF THE MOVING GATE.**
- Test the operator periodically. The gate **MUST** reverse on contact with a rigid object or stop or reverse when an object activates the non-contact sensors. After adjusting the force or the limit of travel, retest the gate operator. Failure to adjust and retest the gate operator properly can increase the risk of injury or death.
- Use the emergency release only when the gate is not moving.
- **KEEP GATES PROPERLY MAINTAINED.** Read the owner's manual. Have a qualified service person make repairs to gate hardware.
- The entrance is for vehicles only. Pedestrians must use separate entrance.
- **SAVE THESE INSTRUCTIONS!**

3.1 - Properly installed safety devices

Safety devices are used to sense, register and prevent damage to vehicular traffic which may block the path of the gate system. If properly installed and inspected for functionality within the prescribed maintenance procedures, the safety devices should prevent the gate system from inflicting harm or damage as a result of its opening and closing action.

3.2 - Safety signs, notices to personnel warning signs

Safety devices must alert all who may enter the gate system area, as to the danger posed by moving equipment. Safety features must be installed and work correctly, such as the infrared beam. This safety device prevents serious injury or death as a result of the gate closing while an object or person blocks the gate operating pathway. An optional flashing lamp that is activated anytime the gate is moving should be added in addition to the aforementioned safety features.

3.3 - Gate system safety devices

Automatic gate operators are designed to move a heavy steel gate. Great amounts of force are sometimes used to move these heavy systems. The automatic gate system may cause significant damage or injury if the path of the gate is obstructed. All sensors, safety devices and warning notices must be in place and operable in order for this system to operate properly. It is the installer's responsibility to install this system properly and to ensure its correct and safe operation.

3.4 - Infrared beams and warning signs

Infrared beams are used to inform the control board that an obstruction is present. Safety devices must be installed properly and inspected periodically to ensure continued reliability and safety. Safety devices, safety sensors, warning signs and notices of moving equipment danger must be installed and readily visible by all paths of approach to the gate system. Failure to post warnings could result in loss of life, damage or physical injury.

3.5 - Establish the location

The installer of this system needs to establish the location of the opener in accordance with instructions contained within this manual. A typical layout is provided at the end of this manual with a nominal basic drawing. It is the installer's responsibility to ensure that the opener is installed in such a fashion so as to prevent binding, pinching or improper articulation of the system throughout its actuation cycle.

3.6 - Read and follow all instructions

3.7 - Keep children away

Never let children operate or play with gate controls. Keep the remote control away from children.

3.8 - Test the gate system

The gate must reverse on contact with a rigid object or stop when an object activates the non-contact sensors. After adjusting the force or the limit of travel, retest the gate operator. Failure to adjust and retest the gate operator properly can increase the risk of injury or death. Test force and correct functionality for photo-eyes and other safety devices at least every 6 months. ONLY USE the MANUAL RELEASE when the gate is not moving or when the unit fails or in case of power outage.

- Turn the power to the gate controller OFF AND REMOVE BATTERIES before using the emergency release.

3.9 - Keep gates properly maintained

Have only a qualified service person make repairs. Unqualified service technicians are not recommended.

4 - PRE-INSTALLATION NOTES

Before installing and/or operating the gate opener, installers and/or users should do the following:

- Confirm the gate operator being installed is appropriate for the application.
- Confirm the gate is designed and built according to current applicable published industry standards.
- Confirm all appropriate features and accessory devices are being incorporated, including both primary and secondary entrapment protection devices.
- Make sure the gate works freely before installing the operator.
- Repair or service worn or damaged gate hardware before installing the operator.
- Adjust the FORCE device to the minimum force setting that allows reliable gate operation.
- Install operator inside fence line (DO NOT install operator on public side of fence line).
- Swinging gates shall not open into public access areas.
- Install a proper electrical ground to a gate operator.
- Install keypad controls where users cannot touch, or reach through gate while operating controls, which is a minimum of 8 feet from the gate.
- Install controls where user has full view of gate operation.
- Install all warning signs (In accordance with UL 325) on both sides of the gate to warn persons in the area of potential hazards associated with automatic vehicular gate operation.

- A minimum of two (2) WARNING SIGNS shall be installed, one on each side of the gate where easily visible.
- Test all features for proper functions before placing the automatic vehicular gate opener into service.
- Demonstrate the basic functions and safety features of the gate system to owners/end users/general contractors, including how to turn off power and how to operate the manual release feature.
- Leave safety instructions, product literature, installation manual and maintenance instructions with end user.
- Explain to the owners/users the importance of a service contract that includes a routine testing of the entire system including the entrapment protection devices, and explain the need for the owners to insure that this testing is performed routinely.
- Offer the owner/end user a maintenance contract, or contact them regularly to offer maintenance.
- See instructions on the placement of non-contact sensors for each type of application.

4.1 - Follow Instructions

Always follow all instructions included in this manual to ensure safety and the longevity of the operator.

4.2 - Intended usage

THIS ACTUATOR IS INTENDED FOR USE WITH VEHICULAR SWING GATES ONLY, WHEN COMBINED WITH A NICE BRAND CONTROL BOARD.

4.3 - Warnings, cautions and notes

- 4.3.1 Gate terms "system", "gate operator", "gate system", and "gate operator system" for these warnings, cautions and notes are intended to cover the gate controller, gate controller software, the gate actuator, and all safety accessories included within a typical installation.
- 4.3.2 Gate system designers, installers and users must take into consideration the inherent hazards associated with each installation, since no two installations will be exactly alike.
- 4.3.3 Improperly designed, constructed, installed or maintained systems can and may introduce hazards which may or may not be readily seen or identified by users, bystanders, installers or inspectors
- 4.3.3 Improperly designed, constructed, installed or maintained systems can and may introduce hazards which may or may not be readily seen or identified by users, bystanders, installers or inspectors
- 4.3.4 All pinch points must be guarded or eliminated.
- 4.3.5 Only install this gate system opener in appropriate manners in which the operation is safe and secure.
- 4.3.6 A gate operator exerts a great amount of force in order to move the gate system in normal operation, therefore appropriate safety sensors, measures, notices and appropriate safety features must be incorporated in all installations.
- 4.3.7 The gate must be installed correctly and no binding or resistance should be present throughout its movement in either direction.
- 4.3.8 The gate system must be installed in an area and in such a manner in which the gate has sufficient clearance to open, close and move without striking or contacting any structures and/or other obstructions.
- 4.3.9 The gate system is designed for vehicular traffic only, and should never, under any situation be used for pedestrian traffic
- 4.3.10 Pedestrian prohibited signs, warning signs or other suitable measures must be used at minimum, to warn pedestrians to stay away from, and to not use this system under any circumstances.
- 4.3.11 Pedestrians should be encouraged to use a pedestrian entry/exit only.
- 4.3.12 Pedestrians should never cross the path of a moving gate. The sensors are designed to prevent contact with a vehicle and are not necessarily capable of preventing contact with a pedestrian. Care should be taken to prevent pedestrian usage under any circumstances.
- 4.3.13 One or more non-contact sensors must be used in any situation or area where entrapment may have the possibility of occurring.
- 4.3.14 Gates shall be constructed in accordance with the provisions given for the appropriate gate type listed, refer to ASTM F2200 for additional gate types.
- 4.3.15 Any existing manual gate latches shall be removed or disabled when an automatic gate system is installed.

- 4.3.16 Protrusions shall not be permitted on any gate, refer to ASTM F2200 for exceptions, if any.
- 4.3.17 Gates shall not be designed, constructed and installed in such a manner that gravity will cause or initiate movement in any direction whether the operator is attached or not.
- 4.3.18 A pedestrian gate shall not, under any circumstances, be attached to, or incorporated into, any vehicular gate system in manner. This also applies to any fence or wall, or any portion thereof, that the gate may cover in the open or closed position.
- 4.3.19 Any non automated gate that is to be automated in any manner should be upgraded to conform to the provisions contained within the provisions of this document and ASTM F2200 as applicable.
- 4.3.20 To reduce the risk of severe injury or death please read and understand this entire manual and your local code requirements prior to starting installation. Additionally, understanding the ASTM standards will assist you in the proper assembly, installation and operation of your gate opening system.
- 4.3.21 Disconnect all electricity and/or all sources of power before performing any maintenance.
- 4.3.22 To reduce the risks of fire or injury always contact the installer or distributor prior to performing any repairs or maintenance.
- 4.3.23 Never operate gate with obstructions present.
- 4.3.24 No one should ever cross the operative path of the gate.
- 4.3.25 Never let children play or linger in the vicinity of the gate or opener equipment.
- 4.3.26 Never operate the gate or the opener when the opener is not operating or adjusted correctly.
- 4.3.27 Never allow children to play with or manipulate gate controls. Keep all remotes away from children.
- 4.3.28 Only use the MANUAL RELEASE when gate is completely stationary. Untrained persons should never touch the gate or any releases if any are installed or applicable.
- 4.3.29 Test the gate operator periodically (once every 6 months minimum). Gate must reverse course or stop immediately upon contact with any source in its path. Gate must stop and reverse course at any time any object or other item crosses the path of the gate. Should the safety sensors not stop and/or reverse the gates travel, immediately investigate and repair the inoperative condition. Gate should not be used under any circumstances, if all sensors and safety devices are not performing to standards illustrated within this manual.
- 4.3.30 Gate should not be used if safety devices are not performing to all local, state and federal guidelines.
- 4.3.31 Replace fuse only with fuse of same type and rating.
- 4.3.32 Installation of this gate system in a manner inconsistent with the manufacturer's recommended instructions, local, State or Federal law transfers the liability unto the installer. Careful consideration has been taken by the manufacturer's to devise safe measures, safe design and incorporate safety measures to prevent injury, death or property damage. By circumventing, ignoring or modifying any safety system or the exclusion thereof, the installer is creating a new untested process outside the purview of the manufacturer and therefore assumes all risk.
- 4.3.33 This unit is not to be installed on any gate, door or other structure which serves to block, secure, close off or otherwise control a pedestrian entry point or access point.
- 4.3.34 Vehicular swing gates shall be designed, constructed and installed in accordance with security related parameters specific to the application in question, with absolute safety in all considerations.
- 4.3.35 Never mount any device that operates the gate opener where the user can reach around, over or through the gate to operate the controls. Controls should be mounted at minimum, 8 feet away from any moving part of the gate or gate system.
- 4.3.36 A hard wired control shall be located in such a manner so that electronic communication between the two is never interrupted or the wires damaged.
- 4.3.37 Any controls used to reset the device after obstruction/entrapment protection incidents should be located within view of the gate and should have safety features that prevent unauthorized use.
- 4.3.38 Never allow anyone to ride, hang on or otherwise touch the gate.
- 4.3.39 Safety sensors must be present at all times. The hard wired safety sensors must be arranged and installed in such a manner so that the communication between gate operator and sensor(s) are never interrupted or severed by mechanical damage or movement. All items which have sensors or safety devices installed must be constructed or installed in such a manner so as to prevent removal or damage. All subsequent sensors must be suitable for the system installed and approved for use.
- 4.3.40 Never increase the force used to move the gate, beyond the absolute minimum required.
- 4.3.41 Never use force adjustments to compensate for binding, sticking or resistant operation. These situations should be addressed and corrected before installation of the gate operator. Gate systems should swing freely in all directions prior to installation of this gate operator.
- 4.3.42 After any adjustment is made, all safety modes/features must be tested. Gate must stop or reverse upon any object crossing the path of the gate or the gate comes into contact with any object.
- 4.3.43 Activate gate only when the gate is in clear view of the user, the gate system is properly adjusted, tested and verified, and there are no obstructions present.
- 4.3.44 Keep gate and gate system properly maintained and properly inspected at all times.
- 4.3.45 This operator is intended for installation only on swing and slide gates used to control vehicular traffic.
- 4.3.46 The gate must be installed in a location so that sufficient clearance is provided between the gate and adjacent structures when opening and closing to reduce the risk of entrapment.
- 4.3.47 The gate must be properly installed and work freely in both directions prior to the installation of the gate operator.
- 4.3.48 Install the gate operator only when the operator is appropriate for the construction and the usage class of the gate.
- 4.3.49 The gate must be properly installed and work freely in both directions prior to the installation of the gate operator.
- 4.3.50 Controls must be far enough from the gate so that the user is prevented from coming in contact with the gate while operating the controls. Controls intended to be used to reset an operator after two sequential activations of the entrapment protection device(s) must be located in the line of sight of the outdoor gate or easily accessible controls shall have a security feature to prevent unauthorized use.
- 4.3.51 All warning signs and placards must be installed where visible in the area of the gate.
- 4.3.52 Care shall be given to reduce the risk of nuisance tripping such as when a vehicle trips the sensor while the gate is still moving
- 4.3.53 All gate systems must utilize a monitored contact or non-contact presence detection sensor.
- 4.3.54 A hardwired contact sensor shall be located and its wiring arranged so that the communication between the sensor and the gate operator is not subject to mechanical damage.
- 4.3.55 Hardwired contact or non-contact sensors to signal the gate actuator of entrapment conditions are recommended.

5 - INSTALLATION PROCEDURES

5.1 - Pivot Arm Installation

IMPORTANT - Never weld parts to the gate or posts when the operator circuit board is powered. Doing so may damage the board beyond repair.

PULL TO OPEN INSTALLATION - PIVOT ARM INSTALLATION - Location of Pivot Point

The following instructions provide up to 105° of swing.

Measurements are taken from the center of pivot of the gate hinge.

The pivot arm needs to be securely mounted to the hinge post or equivalent mounting surface. It is recommended to weld the pivot arm to a metal post. In order to achieve the correct articulation, geometry and rate of speed of the gate it is critical that the measurements below are followed. The pivot arm may need to be cut to achieve the correct placement of the actuator mounting hole. Measurements are taken from the center of pivot of the gate hinge.

NOTE If you have columns built around your gate hinge post, check these measurements for proper clearance before proceeding with this pull to open installation.

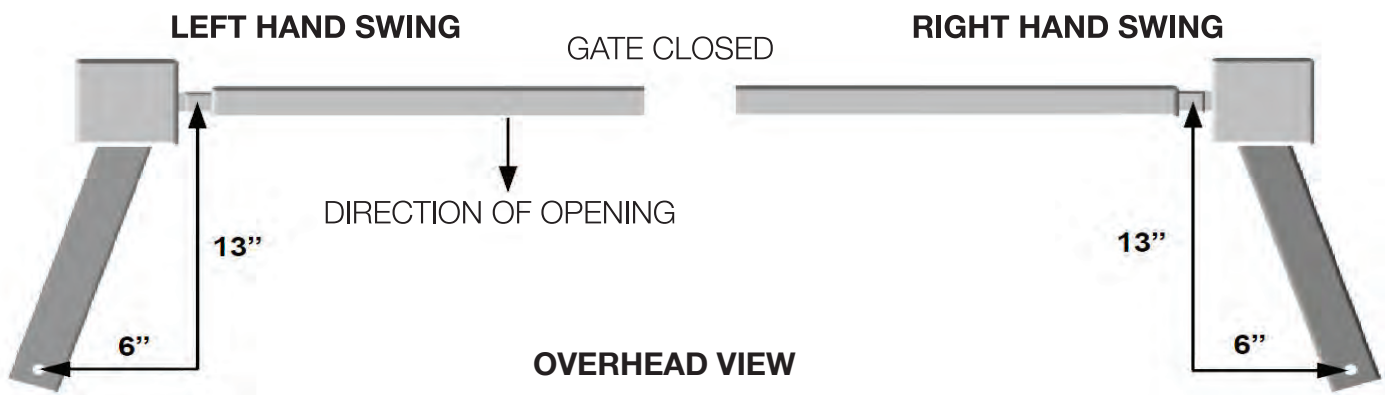

FIGURE 5 - 1 PULL TO OPEN INSTALLATION

VERTICAL POSITION OF PIVOT ARM

The top edge of the Pivot Arm will be located 1/2" below the center line for the gate bracket. The Pivot Arm must be level when secured.

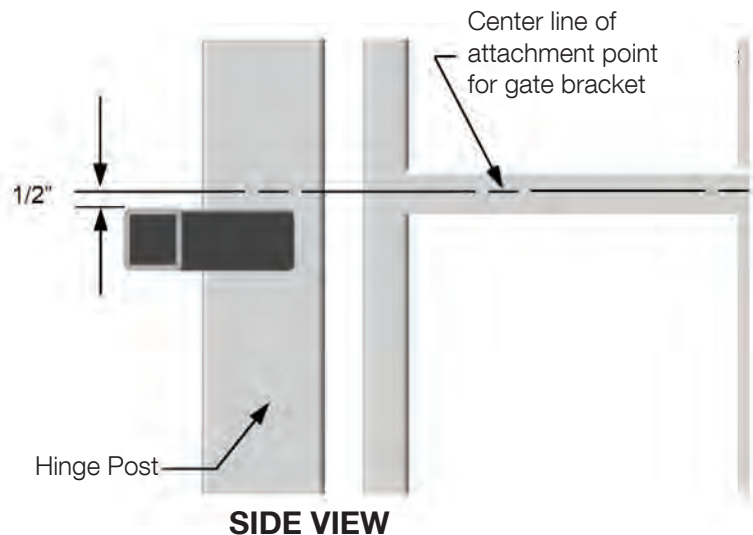

FIGURE 5 - 2 VERTICAL PIVOT POSITION

5.2 - Push to open installation

PIVOT ARM INSTALLATION - Location of Pivot Point

Measurements are taken from the center of pivot of the gate hinge.

The pivot arm needs to be securely mounted to the hinge post or equivalent mounting surface. It is recommended to weld the pivot arm to a metal post. In order to achieve the correct articulation, geometry and rate of speed of the gate it is critical that the measurements below are followed. The pivot arm may need to be cut to achieve the correct placement of the actuator mounting hole. Measurements are taken from the center of pivot of the gate hinge.

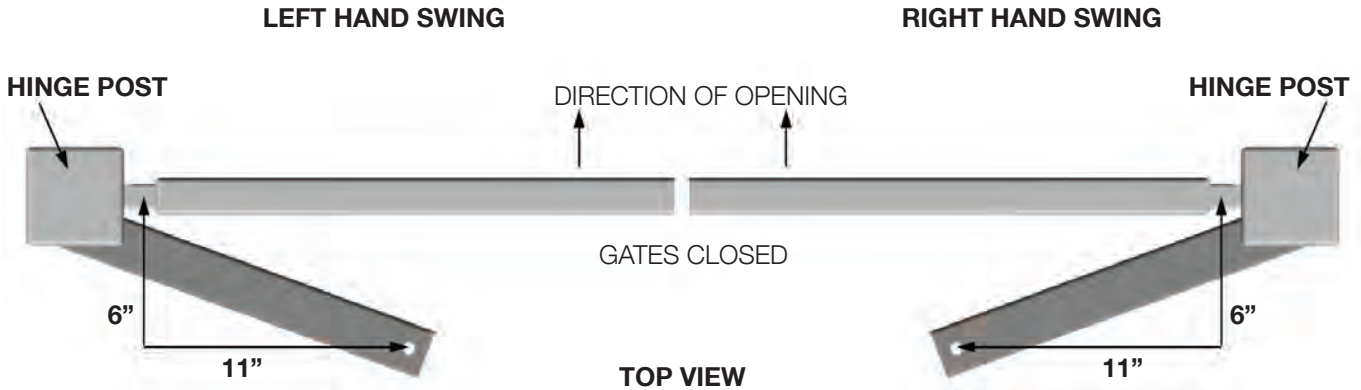

FIGURE 5 - 3 PUSH TO OPEN INSTALLATION

5.3 - Actuator mounting

Mount the actuator to the pivot arm as shown.

Please notice the washer goes below the actuator flange.

The lock nut should be tight to prevent movement or shifting when the actuator is running. This will also prevent excessive "bounce" or "wobble" when the gate stops moving.

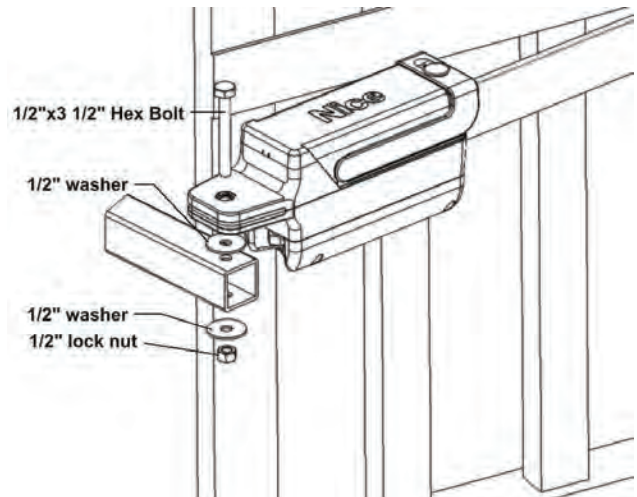

FIGURE 5 - 4 ACTUATOR MOUNTING

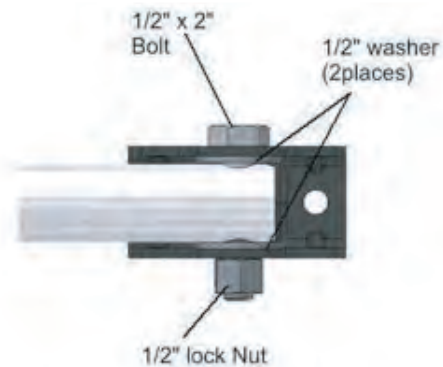
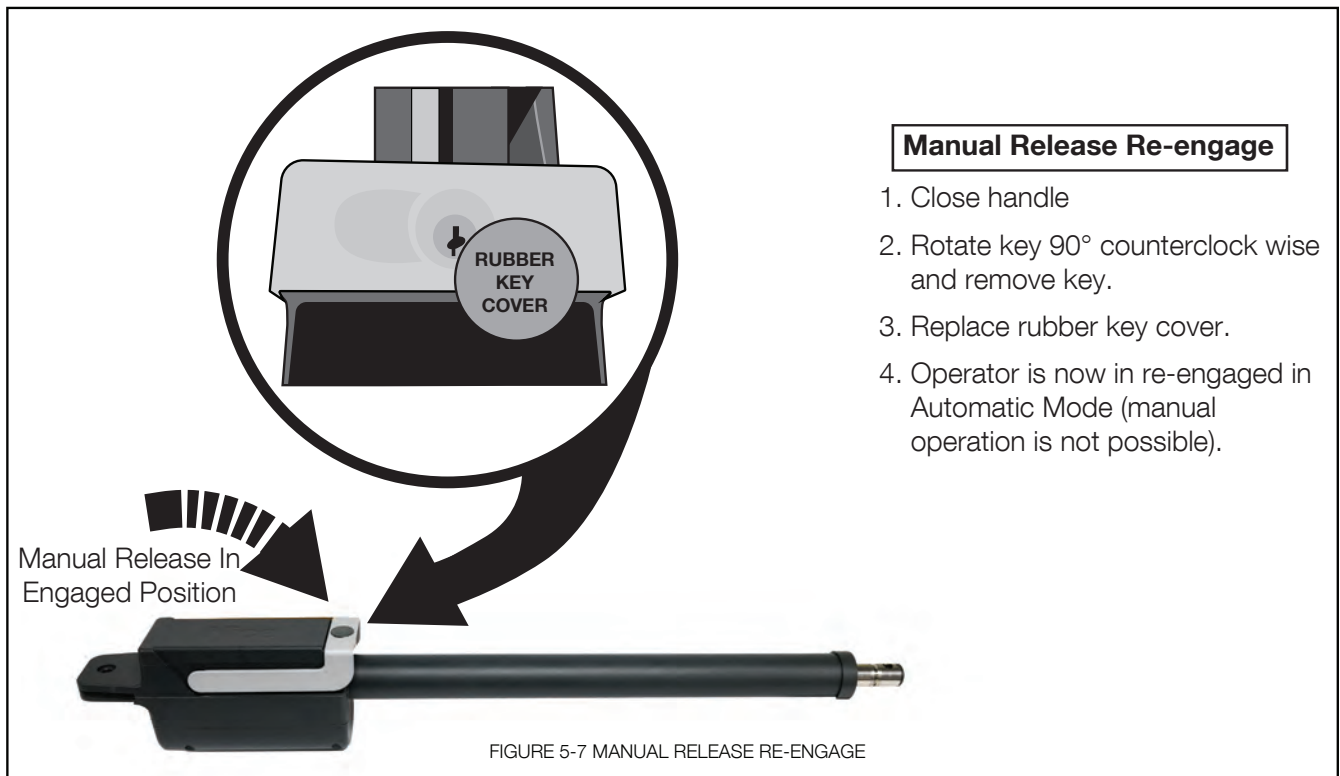
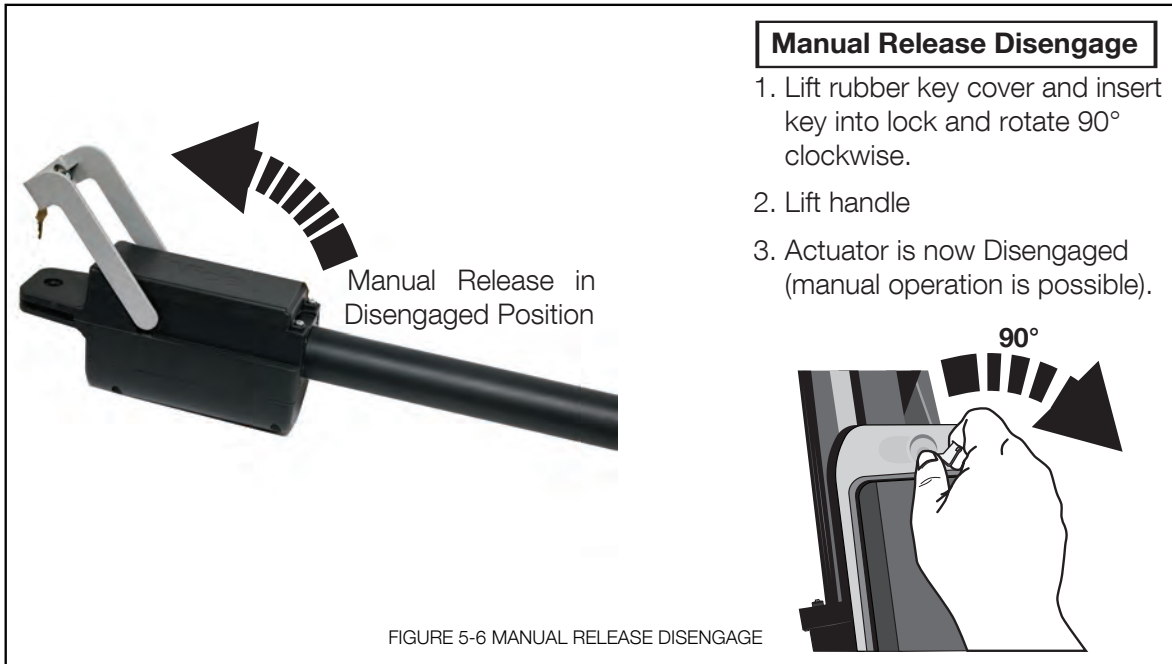

FIGURE 5 - 5 GATE BRACKET MOUNTING

5.4 - Manual release/manual operation



5.5 - Titan actuator wiring

THE FOLLOWING SECTION NEED ONLY BE USED FOR REWIRING IN THE EVENT OF A DESIRED LONGER OR SHORTER CABLE LENGTH.

Using the supplied key, unlock the manual release handle. Lift upwards on the release handle as shown.

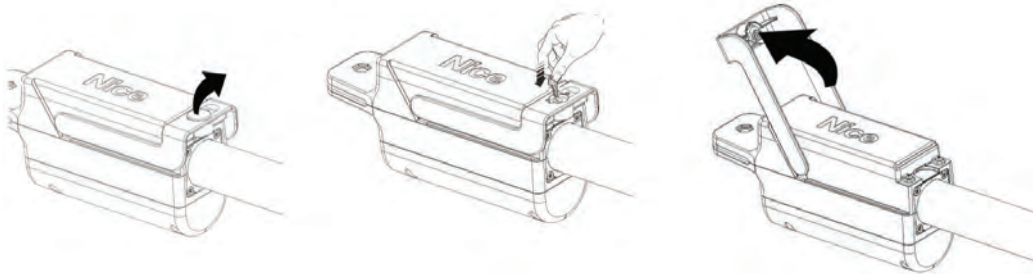

FIGURE 5 - 8 MANUAL RELEASE HANDLE

With the release handle up, remove the screws from the limit cover and remove the cover. On the bottom of the actuator loosen the strain relief nut and insert the wire into the actuator housing. The connections are on the top of the atuator behind the limit assembly.

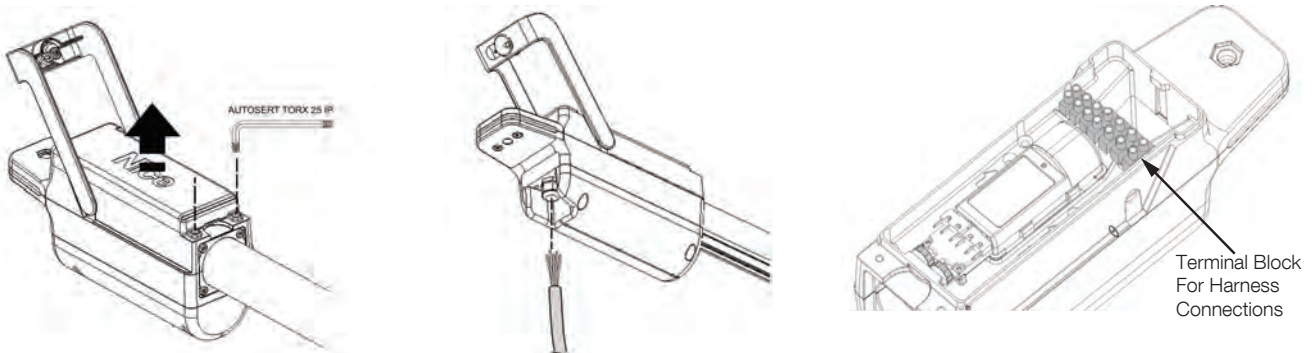
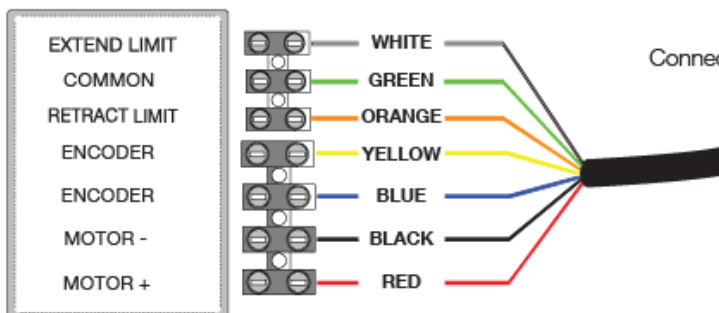

FIGURE 5 - 9 WIRE HARNESS INSERTION



Connect the wiring to the actuator terminal block as shown.

FIGURE 5 - 10 TITAN ACTUATOR WIRING

936 Control Board

FIGURE 5 - 12 WIRING DIAGRAM FOR 936 CONTROL BOARD

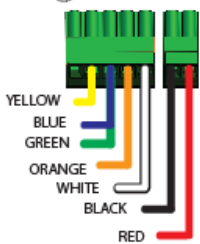
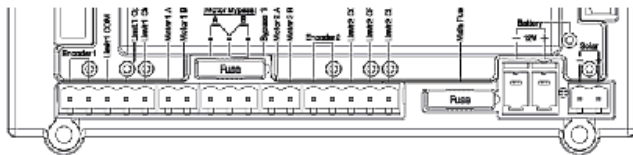
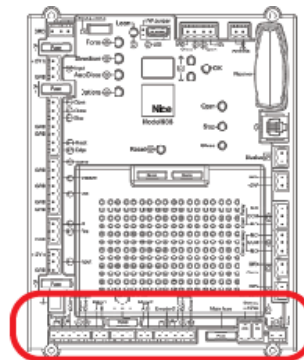

PULL TO OPEN

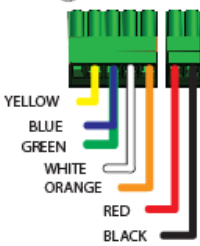
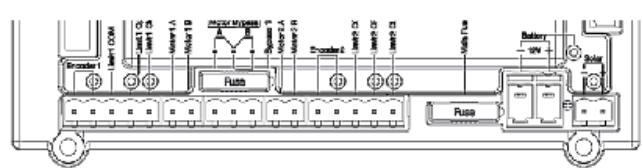

PUSH TO OPEN

5.7 - Limit switch adjustment

BEFORE continuing with this section, make sure to have the MANUAL for the control board specific to this installation in hand.

1. From the manufacturer, these units will be in the fully retracted position.
2. If the actuator is not mounted to the pivot arm, do so at this time, before proceeding (see Sec. 5.3).
 - a. For a standard **pull to open** application, bring the gate leaf to the fully open position.
 - b. For a reversed **push to open** application, bring the gate leaf to the fully closed position.
3. Bring the bracket end of the actuator (with the gate bracket attached) into contact with the gate and mark placement.
4. Remove the extension tube from the bracket and weld or bolt the bracket to the gate using 3/8" bolts, lock washers and nuts.
5. Bolt the extension tube of the operator back into the gate bracket.
6. Disengage the actuator to allow for manual operation (see section 5.4).
7. Remove the top cover to expose the limit assembly.
8. Manually move the gate to the:
 - a. Fully closed position for **pull to open** applications
 - b. Fully open position for **push to open** applications

A clicking sound will be heard as this manual operation is performed. This sound is the extend limit cog (blue) self-adjusting.

9. Manually move the gate back to the:
 - a. Fully open position for **pull to open** applications
 - b. Fully closed position for **push to open** applications
10. Re-engage the actuator to engage the drive train.
11. Plug the actuator into the control board (see Sec. 5.6).
12. Put the control board in hold-to-run (Learn) mode. (refer to control board manual)
13. Remove the plastic dual knob cover and turn the knob controlling the linear motion of the retract limit cog (white) to bring it into contact with the limit switch. If this is done correctly you will see:
 - a. With the 936 control board
 - i. The LED marked Limit 1 Open (or Limit 2 Open if using motor 2) illuminate red indicating the open limit is active for a **pull to open**.
 - ii. The LED marked Limit 1 Close (or Limit 2 Close if using motor 2) illuminate red indicating the close limit is active for a **push to open**.
14. Press and hold:
 - a. The close button until the close limit is activated for a **pull to open** application.
 - b. The open button until the open limit is activated for a **push to open** application.
15. If the location of the gate is not the location desired, disengage the actuator using the manual release lever (sect 5.4), move the gate to the position desired and re-engage the actuator.
16. Turn the knob controlling the linear motion of the extend limit cog (blue) to bring it into contact with the limit switch. If this is done correctly you will see:
 - a. With the 936 control board
 - i. The LED marked Limit 1 Close (or Limit 2 Close if using motor 2) illuminate red indicating the Close limit is active for a **pull to open**.
 - ii. The LED marked Limit 1 Open (or Limit 2 Open if using motor 2) illuminate red indicating the Open limit is active for a **push to open**.

18. If the location of the gate is not the location desired, engage the manual release, move the gate to the position desired and disengage the manual release, then repeat step 12.
19. Consult the control board manual for instruction regarding the particular learn procedure.

Steps 9 thru 16 may need to be repeated if the open and close positions established during the learn cycle need adjustment.

***Once the operator has been learned and the location of the limits is correct, replace the dual knob cover and top cover.**

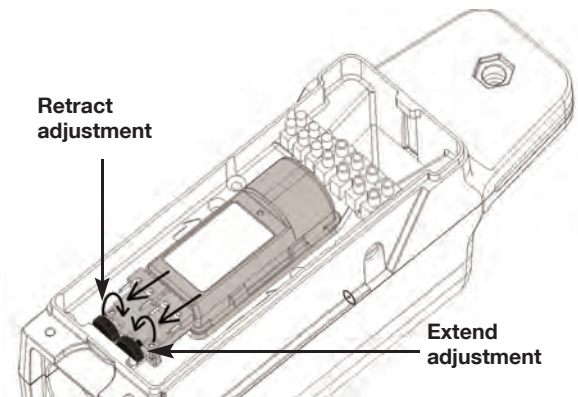

FIGURE 5 - 13 LIMIT SWITCH ADJUSTMENT

NOTE

Turning the knob in the direction shown above will move the limit cog toward the limit switch

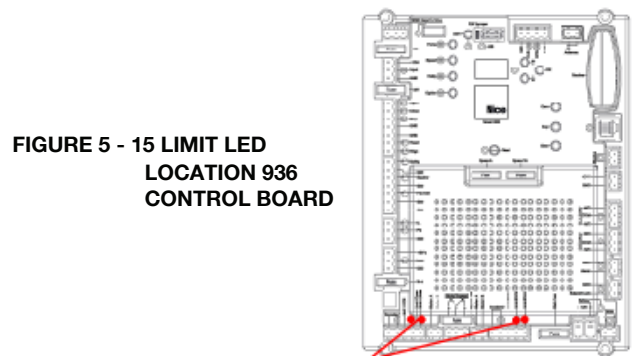

FIGURE 5 - 15 LIMIT LED LOCATION 936 CONTROL BOARD

936 Limit LEDs

6- GENERAL LAYOUT AND SAFETY ACCESS

Entrapment Protection Inputs - Typical Installation Diagram Utilizing Loop Sensors and Photocells

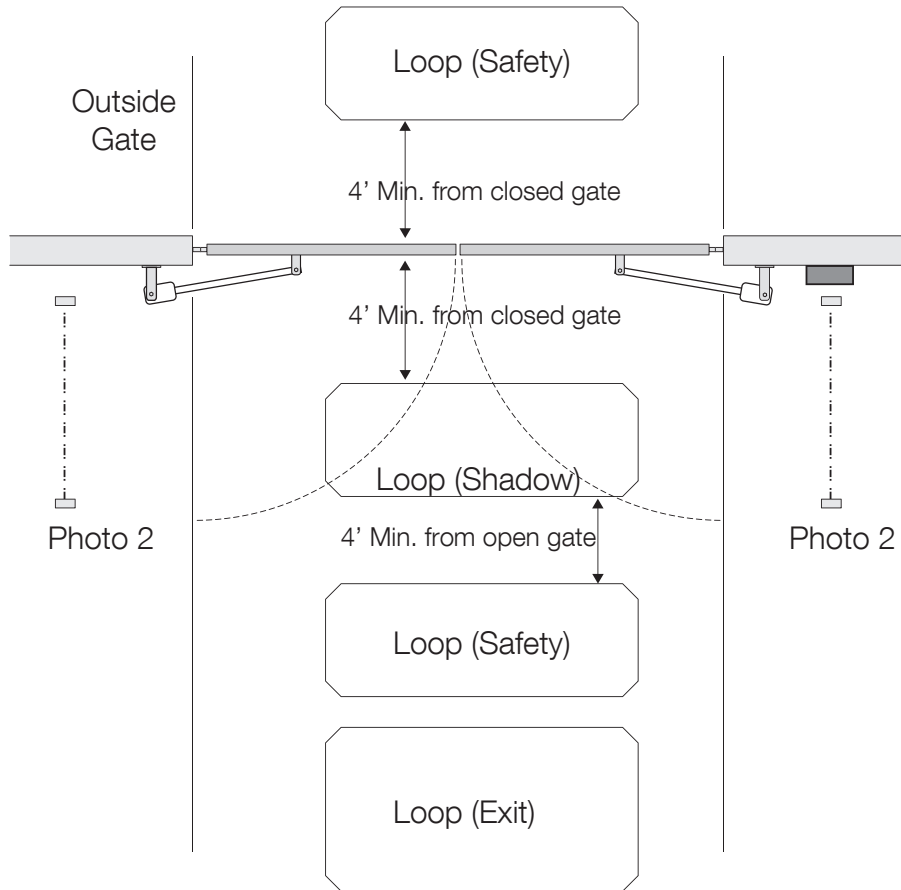

FIGURE 6 -1 LAYOUT FOR IN-GROUND LOOPS

Entrapment Protection Inputs - Typical Installation Diagram Utilizing Photocells

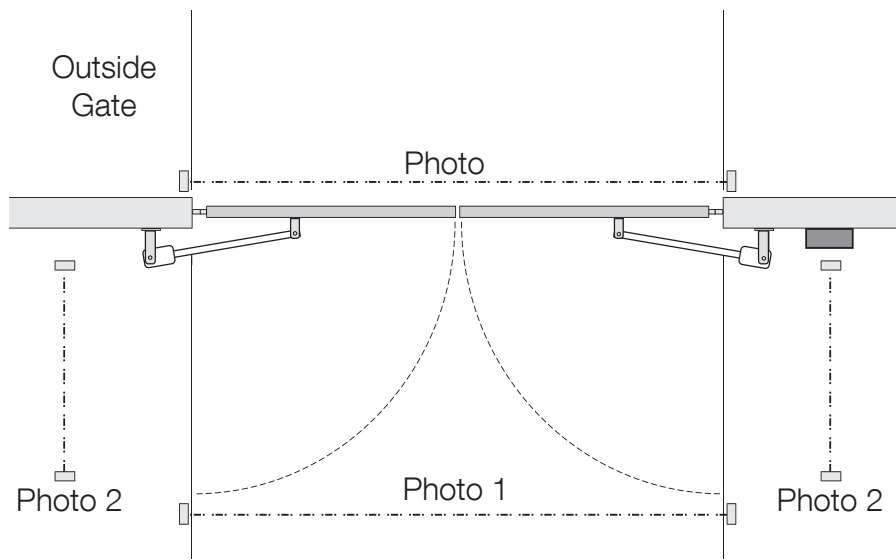

FIGURE 6 -2 LAYOUT FOR PHOTOCELLS

SECTION 7 - ACCESSORIES AND SENSORS

EXTERNAL ENTRAPMENT PROTECTION

Non-contact and contact sensors must be installed individually or in combination with each other to provide external entrapment protection.

Care should be exercised to reduce the risk of nuisance tripping, such as when a vehicle trips the sensor while the gate is still moving, and one or more contact sensors shall be located where the risk of entrapment or obstruction exists, such as the perimeter reachable by a moving gate or barrier.

A hardwired contact sensor shall be located and its wiring arranged so that the communication between the sensor and the gate operator is not subjected to mechanical damage.

A wireless contact sensor such as one that transmits radio frequency (RF) signals to the gate operator for entrapment protection functions shall be located where the transmission of the signals are not obstructed or impeded by building structures, natural landscaping or similar obstruction.

DURING INSTALLATION

- DISCONNECT POWER at the control panel before making any electric service power connection.
- Be aware of all moving parts and avoid close proximity to any pinch points.
- Know how to operate the manual release.
- Adjust the unit to use the minimum force required to operate the gate smoothly even during mid-travel reversing.
- Place controls a minimum of 8 feet away from the gate so that the user can see the gate and operate controls but cannot touch the gate or gate operator while operating the controls.
- Warning signs must be placed on each side of the gate or in high-visibility areas to alert of automatic gate operations.

**⚠ WARNING
AVERTISSEMENT**

ES096100

Moving Gate can cause Serious Injury or Death.

Persons are to keep clear! The gate is able to be moved without prior warning.
Do not allow children to operate gate or play in gate area.
This entrance is for vehicles only. Pedestrians must use separate entrance.
Persons are to read the owner's manual and safety instructions.

Le portail en mouvement peut causer des blessures graves ou la mort.

Les personnes ne devront pas s'approcher!
Le portail est capable d'être bougé sans avertissement préalable.
Ne pas laisser les enfants utiliser le portail ou jouer dans le domaine du portail.
Cette entrée est réservée aux véhicules.
Les piétons devront utiliser une entrée séparée.
L'utilisateur doit lire le manuel d'utilisation et les instructions de sécurité.

8- INSPECTION AND OPERATION

Proper inspection of all equipment is required to ensure continuous functionality, safety and to ensure reliable operation in all weather conditions. Inspect electrical assemblies and wiring installations for damage, general condition, and proper functioning to ensure the continued satisfactory operation of the electrical system. Adjust, repair, overhaul, and test electrical equipment and systems in accordance with the recommendations and procedures in the gate operator system and/or component manufacturer's maintenance instructions.

Replace components of the electrical system that are damaged or defective with identical parts, with manufacturer's approved equipment, or its equivalent to the original in operating characteristics, mechanical strength, and environmental specifications. A partial list of suggested problems to look for and checks to be performed are listed below:

Damaged, discolored, or overheated equipment, connections, wiring, bearing caps and installations.

Excessive heat or discoloration at high current carrying connections. (look for bluing or heat affected metal).

Misalignment of electrically driven equipment. (Causes strain on pulley assemblies and bearings).

Poor electrical bonding (broken, disconnected or corroded bonding strap) and grounding, including evidence of corrosion.

Dirty equipment and connections. Clean equipment and connections.

Improper, broken, inadequately supported equipment, wiring and conduit, loose connections of terminals, and loose ferrules.

Poor mechanical or weld joints. Broken welds.

Condition of circuit breaker and fuses. Ensure that they are of the correct type and amperage.

Insufficient clearance between exposed current carrying parts and ground or poor insulation of exposed terminals. All exposed connections must be covered (prevent arcing between exposed parts, and electrical shock).

Broken or missing wire, connectors, etc.

Operational check of electrically operated equipment such as motors, inverters, generators, batteries, lights, protective devices, etc. Ensure proper functionality of all systems during inspections.

Ensure safety placards and warning signs are present as specified within this document. Ensure proper functionality of all safety devices as specified. Non-functioning or malfunctioning safety devices should be replaced immediately.

9 - EMERGENCY VEHICLE ACCESS

The automatic vehicular gate system must be designed to allow access to emergency vehicles under different operating conditions.

During normal powered operation, emergency vehicles access the gate by use of the emergency vehicle access device installed on your gate system. The type of device that is used in your community is dependent on your city codes. These devices may include (but are not limited to) Fire Department lock boxes, Click-2-Enter radio receivers, strobe light sensors, siren sensors, etc.

Check with your installer to determine if your gate system is equipped with a back-up power system. In the event of a primary (AC) power failure and a back-up system (DC) power failure (low charged or dead batteries for example), the system must have a release system to allow the gate to be manually operated. The release device must be accessible from either side of the gate and must be present so that emergency personnel can gain access through the gate under this condition.

If applicable, this system is equipped with a manual release system that will allow the gate to be pushed open in the event of a power outage or equipment failure.

NOTE: Never attempt to manually push open any gate with an operator attached to it until you have verified that power to the operator has been shut-off.

The automatic vehicular gate system must be designed to allow access to emergency vehicles under different operating conditions.

In the event of a power failure, the emergency vehicle access device may not be functional because the gate operator is not powered.

NOTE: DC powered back-up systems are optional and your gate system may or may not be equipped with one. Check with your installer to determine if your gate system is equipped with a back-up power system.

For manual fail-safe gate operation, turn power to the operator OFF. If a backup power system is in use, be sure that this power is turned OFF also or disconnected. Once power is OFF, the gate can be manually operated by engaging the manual release lever (see section 5.4).